

DE	Gebrauchsanleitung / Montageanleitung	2
FR	Mode d'emploi / Instructions de montage	3
EN	Instructions for use / assembly instructions	4
IT	Istruzioni per l'uso / Istruzioni per Installazione	5
ES	Modo de empleo / Instrucciones de montaje	6
NL	Gebruiksaanwijzing / Handleiding	7
DK	Brugsanvisning / Monteringsvejledning	8
PT	Instruções para uso / Manual de Instalação	9
PL	Instrukcja obsługi / Instrukcja montażu	10
CS	Návod k použití / Montážní návod	11
SK	Návod na použitie / Montážny návod	12
ZH	用户手册 / 组装说明	13
RU	Руководство пользователя / Инструкция по монтажу	14
FI	Käyttöohje / Asennusohje	15
SV	Bruksanvisning / Monteringsanvisning	16
LT	Vartotojo instrukcija / Montavimo instrukcijos	17
HR	Upute za uporabu / Uputstva za instalaciju	18
TR	Kullanım kılavuzu / Montaj kılavuzu	19
RO	Manual de utilizare / Instrucțiuni de montare	20
EL	Οδηγίες χρήσης / Οδηγία συναρμολόγησης	21
SI	Navodilo za uporabo / Navodila za montažo	22
ET	Kasutusjuhend / Paigaldusjuhend	23
LV	Lietošanas pamācība / Montāžas instrukcija	24
SR	Uputstvo za upotrebu / Uputstvo za montažu	25
NO	Bruksanvisning / Montasjeveiledning	26
BG	Инструкция за употреба / Ръководство за монтаж	27
SQ	Udhëzuesi i përdorimit / Udhëzime rreth montimit	28
AR	دليل الاستخدام / تعليمات التجميع	29
HU	Használati útmutató / Szerelési útmutató	30
JP	取扱説明書 / 施工説明書	32

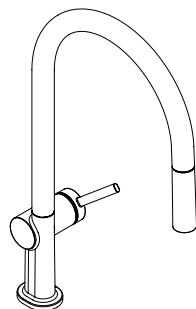

Talis M54 210 1jet sBox
72803XXX / 72848000

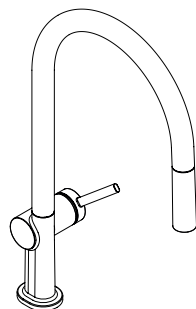

Talis M54 210 2jet sBox
72801XXX / 72847000

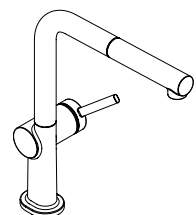

Talis M54 270 1jet sBox
72809XXX / 72849000



Sicherheitshinweise

- ⚠ Bei der Montage müssen zur Vermeidung von Quetsch- und Schnittverletzungen Handschuhe getragen werden.
- ⚠ Große Druckunterschiede zwischen den Kalt- und Warmwasseranschlüssen müssen ausgeglichen werden.

Montagehinweise

- Vor der Montage muss das Produkt auf Transportschäden untersucht werden. Nach dem Einbau werden keine Transport- oder Oberflächenschäden anerkannt.
- Die Leitungen und die Armatur müssen nach den gültigen Normen montiert, gespült und geprüft werden.
- Die in den Ländern jeweils gültigen Installationsrichtlinien sind einzuhalten.

Technische Daten

Betriebsdruck: max. 1 MPa
 Empfohlener Betriebsdruck: 0,1 - 0,5 MPa
 Prüfdruck: 1,6 MPa
 (1 MPa = 10 bar = 147 PSI)

Heißwassertemperatur: max. 60 °C
 Thermische Desinfektion: 70 °C / 4 min

Das Produkt ist ausschließlich für Trinkwasser konzipiert!

Symbolerklärung



Kein essigsäurehaltiges Silikon verwenden!



Justierung (siehe Seite 42)

Einstellen der Warmwasserbegrenzung. In Verbindung mit Durchlauferhitzern ist eine Warmwassersperre nicht zu empfehlen.



Wartung (siehe Seite 54)

Rückflussverhinderer müssen gemäß EN 806-5 regelmäßig in Übereinstimmung mit nationalen oder regionalen Bestimmungen auf ihre Funktion geprüft werden (mindestens einmal jährlich).



Maße (siehe Seite 43)



Durchflussdiagramm
(siehe Seite 43)



Serviceteile (siehe Seite 51)

XXX = Farbcodierung
 000 = Chrom
 340 = Brushed Black Chrome
 670 = Mattschwarz
 800 = Edelstahl-Optik

Sonderzubehör

(nicht im Lieferumfang enthalten)



F12 Verlängerung #43333000
(siehe Seite 49)



Reinigung (siehe Seite 47)



Bedienung (siehe Seite 50)

Hansgrohe empfiehlt, morgens oder nach längeren Stagnationszeiten den ersten halben Liter nicht als Trinkwasser zu verwenden.



Prüfzeichen (siehe Seite 56)

Störung

Ursache

Abhilfe

Armatur schwergängig	- Kartusche defekt, verkalkt	- Kartusche austauschen
Armatur tropft	- Kartusche defekt	- Kartusche austauschen
Wasseraustritt am Befestigungsschaft	- Anschlusschläuche nicht ganz in den Grundkörper eingeschraubt	- Anschlusschläuche von Hand festziehen
	- O-Ring am Anschlusschlauch defekt	- O-Ring austauschen
Zu niedrige Warmwassertemperatur	- Warmwasserbegrenzung falsch eingestellt	- Warmwasserbegrenzung einstellen



Consignes de sécurité

- ⚠ Lors du montage, porter des gants de protection pour éviter toute blessure par écrasement ou coupure.
- ⚠ Il est conseillé d'équilibrer les pressions de l'eau chaude et froide.

Instructions pour le montage

- Avant son montage, s'assurer que le produit n'a subi aucun dommage pendant le transport. Après le montage, tout dommage de transport ou de surface ne pourra pas être reconnu.
- Les conduites et la robinetterie doivent être montés, rincés et contrôlés selon les normes en vigueur.
- Les directives d'installation en vigueur dans le pays concerné doivent être respectées.

Informations techniques

Pression de service autorisée: max. 1 MPa
 Pression de service conseillée: 0,1 - 0,5 MPa
 Pression maximum de contrôle: 1,6 MPa
 (1 MPa = 10 bar = 147 PSI)
 Température d'eau chaude: max. 60 °C
 Désinfection thermique: 70 °C / 4 min
 Le produit est exclusivement conçu pour de l'eau potable!

Description du symbole



Ne pas utiliser de silicone contenant de l'acide acétique!



Etalonnage (voir pages 42)

Réglage de la limitation d'eau chaude. En liaison avec les chauffe-eau, un blocage de l'eau chaude n'est pas recommandable.



Entretien (voir pages 54)

Les clapets anti-retour doivent être examinés régulièrement conformément à la norme EN 806-5 ou conformément aux dispositions nationales ou régionales quant à leur fonction (au moins une fois par an).



Dimensions (voir pages 43)



Diagramme du débit
(voir pages 43)



Pièces détachées (voir pages 51)

XXX = Couleurs
 000 = Chromé
 340 = Brushed Black Chrome
 670 = Matt Black
 800 = Aspect Acier Inox

Accessoires en option

(ne fait pas partie de la fourniture)



F12 jeu de rallonge
 #43333000 (voir pages 49)



Nettoyage (voir pages 47)



Instructions de service
(voir pages 50)

Hansgrohe recommande de ne pas utiliser le premier demi-litre le matin ou après une période de stagnation prolongée.



Classification acoustique et débit
(voir pages 56)

Dysfonctionnement	Origine	Solution
Dureté de fonctionnement	- Cartouche défectueuse, entartrée	- Changer la cartouche
Le mitigeur goutte	- Cartouche défectueuse	- Changer la cartouche
Fuite à la fixation sous le mitigeur	- Les flexibles de raccordement ne sont pas correctement vissés dans le corps.	- Resserer le flexible à la main.
	- Joint torique sous les flexibles de raccords défectueux	- Changer le joint torique
Température d'eau chaude trop basse, pas d'eau froide	- Limiteur de température mal positionné	- Positionner le limiteur de température



Safety Notes

- △ Gloves should be worn during installation to prevent crushing and cutting injuries.
- △ The hot and cold supplies must be of equal pressures.

Installation Instructions

- Prior to installation, inspect the product for transport damages. After it has been installed, no transport or surface damage will be honoured.
- The pipes and the fixture must be installed, flushed and tested as per the applicable standards.
- The plumbing codes applicable in the respective countries must be observed.

Technical Data

Operating pressure: max. 1 MPa
 Recommended operating pressure: 0,1 - 0,5 MPa
 Test pressure: 1,6 MPa
 (1 MPa = 10 bar = 147 PSI)

Hot water temperature: max. 60°C
 Thermal disinfection: 70°C / 4 min

The product is exclusively designed for drinking water!

Symbol description



Do not use silicone containing acetic acid!



Adjustment (see page 42)

To adjust the hot water limiter. Using a hot water limiter in combination with a continuous flow water heater is not recommended.



Maintenance (see page 54)

The check valves must be checked regularly according to EN 806-5 in accordance with national or regional regulations (at least once a year).



Dimensions (see page 43)



Flow diagram (see page 43)



Spare parts (see page 51)

XXX = Colors
 000 = Chrome Plated
 340 = Brushed Black Chrome
 670 = Matt Black
 800 = Stainless Steel Optic

Special accessories (order as an extra)



F12 extension #43333000 (see page 49)



Cleaning (see page 47)



Operation (see page 50)

Hansgrohe recommends not to use as drinking water the first half liter of water drawn in the morning or after a prolonged period of non-use.



Test certificate (see page 56)

Fault

Cause

Remedy

Mixer stiff	- Cartridge defective, calcified	- Exchange cartridge
Mixer dripping	- Cartridge defective	- Exchange cartridge
Water escaping at the threaded base	- connection hoses not completely screwed into basic body	- Tighten connection hoses by hand
	- O-ring at the connection hose defective.	- Exchange O-ring
Hot water temperature too low	- Hot water limiter incorrectly set	- Set hot water limiter



Indicazioni sulla sicurezza

- ⚠ Durante il montaggio, per evitare ferite da schiacciamento e da taglio bisogna indossare guanti protettivi.
- ⚠ Attenzione! Compensare le differenze di pressione tra i collegamenti dell'acqua fredda e dell'acqua calda.

Istruzioni per il montaggio

- Prima del montaggio è necessario controllare che non ci siano stati danni durante il trasporto. Una volta eseguito il montaggio, non verranno riconosciuti eventuali danni di trasporto o delle superfici.
- Montare, lavare e controllare tubature e rubinetteria rispettando le norme correnti.
- Vanno rispettate le direttive di installazione nazionali vigenti nel rispettivo paese.

Dati tecnici

Pressione d'uso: max. 1 MPa
 Pressione d'uso consigliata: 0,1 - 0,5 MPa
 Pressione di prova: 1,6 MPa
 (1 MPa = 10 bar = 147 PSI)

Temperatura dell'acqua calda: max. 60°C

Disinfezione termica: 70°C / 4 min

Il prodotto è concepito esclusivamente per acqua potabile!

Descrizione simbolo



Non utilizzare silicone contenente acido acetico!



Taratura (vedi pagg. 42)

Regolazione del limitatore di erogazione d'acqua calda. Un limitatore di erogazione di acqua calda in combinazione con le caldaie istantanee non è consigliabile.



Manutenzione (vedi pagg. 54)

La valvola di non ritorno deve essere controllata regolarmente come da EN 806-5, secondo le normative nazionali e regionali (almeno una volta all'anno).



Ingombri (vedi pagg. 43)



Diagramma flusso (vedi pagg. 43)



Parti di ricambio (vedi pagg. 51)

XXX = Trattamento
 000 = Cromato
 340 = Brushed Black Chrome
 670 = Matt Black
 800 = Acciaio Inox Acciaio

Accessori speciali

(non contenuto nel volume di fornitura)



F12 prolunga #43333000 (vedi pagg. 49)



Pulitura (vedi pagg. 47)



Procedura (vedi pagg. 50)

Hansgrohe raccomanda, di mattina oppure dopo lunghi tempi di stagnazione, di non utilizzare il primo mezzo litro come acqua potabile.



Segno di verifica (vedi pagg. 56)

Problema	Possibile causa	Rimedio
Miscelatore duro	- Cartuccia difettosa	- Sostituire la cartuccia
Miscelatore gocciola	- Cartuccia difettosa	- Sostituire la cartuccia
Perdita di acqua al set di fissaggio	- I raccordi dei flessibili avvitati male nel corpo incasso	- Avvitare i raccordi flessibili a mano
	- O-ring al raccordo flessibile difettoso	- Sostituire l'o-ring
Temperatura dell'acqua calda	- Limitazione dell'acqua calda regolata male	- Regolare la limitazione dell'acqua calda



Indicaciones de seguridad

- ⚠ Durante el montaje deben utilizarse guantes para evitar heridas por aplastamiento o corte.
- ⚠ Grandes diferencias de presión en servicio entre agua fría y agua caliente deben equilibrarse.

Indicaciones para el montaje

- Antes del montaje se debe examinar el producto contra daños de transporte. Después de la instalación no se reconoce ningún daño de transporte o de superficie.
- Los conductos y la grifería deben montarse, lavarse y comprobarse según las normas vigentes.
- Es obligatorio el cumplimiento de las directrices de instalación vigentes en el país respectivo.

Datos técnicos

Presión en servicio: max. 1 MPa
 Presión recomendada en servicio: 0,1 - 0,5 MPa
 Presión de prueba: 1,6 MPa
 (1 MPa = 10 bar = 147 PSI)
 Temperatura del agua caliente: max. 60 °C
 Desinfección térmica: 70 °C / 4 min
 El producto ha sido concebido exclusivamente para agua potable.

Descripción de símbolos



No utilizar silicona que contiene ácido acético!



Ajuste (ver página 42)

Ajuste del límite de agua caliente. En combinación con calentadores continuos no es recomendable utilizar un bloqueo de agua caliente.



Mantenimiento (ver página 54)

Las válvulas anti-retorno tienen que ser controladas regularmente según la norma EN 806-5, en acuerdo

con las regulaciones nacionales o regionales (una vez al año, por lo menos).



Dimensiones (ver página 43)



Diagrama de circulación (ver página 43)



Repuestos (ver página 51)

XXX = Acabados
 000 = Cromado
 340 = Brushed Black Chrome
 670 = Matt Black
 800 = Acero Especial

Opcional (no incluido en el suministro)



F12 Prolongación
 #43333000 (ver página 49)



Limpiar (ver página 47)



Manejo (ver página 50)

Hansgrohe recomienda no utilizar el primer medio litro como agua potable por las mañanas o tras un largo periodo de inactividad.



Marca de verificación (ver página 56)

Problema	Causa	Solución
Manecilla va dura	- cartucho dañado	- cambiar el cartucho
Grifo pierde agua	- cartucho dañado	- cambiar el cartucho
Pérdida de agua en el set de fijación	- Conexión flexible mal atornillada al cuerpo del caño.	- Apretar a mano la conexión flexible
	- Daños en la junta de la conexión flexible	- cambiar juntas
Temperatura del agua caliente demasiado baja	- tope de agua caliente mal	- ajustar tope



Veiligheidsinstructies

- △ Bij de montage moeten ter voorkoming van knel- en snijwonden handschoenen worden gedragen.
- △ Grote drukverschillen tussen de koud- en warmwater-toevoer dienen vermeden te worden.

Montage-instructies

- Vóór de montage moet het product gecontroleerd worden op transportschade. Na de inbouw wordt geen transport- of oppervlakteschade meer aanvaard.
- De leidingen en armaturen moeten gemonteerd, gespoeld en gecontroleerd worden volgens de geldige normen.
- De in de overeenkomstige landen geldende installatierichtlijnen moeten nageleefd worden.

Technische gegevens

Werkdruk: max. 1 MPa
 Aanbevolen werkdruk: 0,1 - 0,5 MPa
 Getest bij: 1,6 MPa
 (1 MPa = 10 bar = 147 PSI)

Temperatuur warm water: max. 60 °C
 Thermische desinfectie: 70 °C / 4 min

Het product is uitsluitend ontworpen voor drinkwater!

Symboolbeschrijving

 Gebruik geen zuurhoudende silicone!

Instellen (zie blz. 42)

Instellen van de warmwaterbegrenzing. In combinatie met een doorstroomer is een warmwaterblokkering niet aanbevelenswaardig.

Onderhoud (zie blz. 54)

Keerklappen moeten volgens EN 806-5 regelmatig en volgens plaatselijk geldende eisen op het functioneren gecontroleerd worden. (Tenminste een keer per jaar)

Maten (zie blz. 43)

Doorstroomdiagram (zie blz. 43)

Service onderdelen (zie blz. 51)

XXX = Kleuren
 000 = Verchroomd
 340 = Brushed Black Chrome
 670 = Matt Black
 800 = RVS-look

Toebehoren

(behoort niet tot het leveringspakket)

 F12 Verlengstuk #43333000 (zie blz. 49)

 Reinigen (zie blz. 47)

 Bediening (zie blz. 50)

Hansgrohe raadt aan om 's morgens na langere stagnatietijden de eerste halve liter niet als drinkwater te gebruiken.

 **Keurmerk** (zie blz. 56)

Storing	Oorzaak	Oplossing
Bediening zwaar	- Kardoes defect of verkalkt	- Kardoes uitwisselen
Mengkraan lekt	- Kardoes defect	- Kardoes uitwisselen
Lekkage op montageschacht	- Aansluitlangen niet geheel in kraanhuis vastgedraaid	- Aansluitlangen handvast aandraaien
	- O-ring van aansluitlang defect	- O-ring uitwisselen
Temperatuur van warm water te laag	- Heetwaterbegrenzer verkeerd ingesteld	- Heetwaterbegrenzer instellen



Sikkerhedsanvisninger

- △ Ved monteringen skal der bruges handsker for at undgå kvæstelser og snitsår.
- △ Større trykforskelle mellem koldt og varmt vand bør udjævnes.

Monteringsanvisninger

- Før monteringen skal produktet kontrolleres for transportskader. Efter monteringen godkendes transportskader eller skader på overfladen ikke længere.
- Ledningerne og armaturerne skal monteres, skylles og kontrolleres iht. de gældende standarder.
- Installationsbestemmelserne, der gælder i det enkelte land, skal overholdes.

Tekniske data

Driftstryk:	max. 1 MPa
Anbefalet driftstryk:	0,1 - 0,5 MPa
Prøvetryk:	1,6 MPa
	(1 MPa = 10 bar = 147 PSI)
Varmvandstemperatur:	max. 60 °C
Termisk desinfektion:	70 °C / 4 min

Produktet er udelukkende beregnet til drikkevand!

Symbolbeskrivelse



Der må ikke benyttes eddikesyreholdig silikone!



Forindstilling (se s. 42)

Indstilling af varmvandsbegrænsningen. I forbindelse med gennemstrømningsvandvarmere anbefaler vi ikke en varmvandsspærre.



Service (se s. 54)

Ifølge EN 806-5 skal gennemstrømningsbegrænsere i overensstemmelse med nationale regler afprøves regelmæssigt (mindst en gang om året).



Målene (se s. 43)

Gennemstrømningsdiagram (se s. 43)



Reservedele (se s. 51)

- XXX = Overflade
- 000 = Krom
- 340 = Brushed Black Chrome
- 670 = Matt Black
- 800 = Stainless Steel Optic

Specialtilbehør (ikke med i leveringsomfang)



F12 Forlængersæt #43333000 (se s. 49)



Rengøring (se s. 47)



Brugsanvisning (se s. 50)

Hansgrohe anbefaler at den første halve liter om morgenen eller efter længere stagneringstider ikke anvendes som drikkevand.



Godkendelse (se s. 56)

Fejl	Årsag	Hjælp
Grebet går trægt	- Kartusche defekt, tilkalket	- Udskift kartusche
Armaturet drypper	- Defekt kartusche	- Udskift kartusche
Armaturet er utæt ved befæstelsesdelene	- Tilslutningsslangerne er ikke skruet korrekt op i armaturet.	- Med håndkraft skures tilslutningsslangen strammere på.
	- Defekt o-ring på tilslutningsslange	- Udskift o-ring
For lav varmvands-temperatur	- Varmtvandsbegrænsningen er forkert indstillet	- Indstil varmvandsbegrænsningen



Avisos de segurança

- △ Durante a montagem devem ser utilizadas luvas de protecção, de modo a evitar ferimentos resultantes de entalamentos e de cortes.
- △ Grandes diferenças entre as pressões das águas quente e fria devem ser compensadas.

Avisos de montagem

- Antes da montagem deve-se controlar o produto relativamente a danos de transporte. Após a montagem não são aceites quaisquer danos de transporte ou de superfície.
- As tubagens e a torneira têm que ser montadas, enxaguadas e verificadas de acordo com as normas em vigor.
- A prescrições de instalação válidas nos respetivos países devem ser respeitadas.

Dados Técnicos

Pressão de funcionamento: max. 1 MPa
 Pressão de func. recomendada: 0,1 - 0,5 MPa
 Pressão testada: 1,6 MPa
 (1 MPa = 10 bar = 147 PSI)

Temperatura da água quente: max. 60 °C
 Desinfecção térmica: 70 °C / 4 min

Este produto foi única e exclusivamente concebido para água potável!

Descrição do símbolo



Não utilizar silicone que contenha ácido acético!



Afinação (ver página 42)

Ajuste do limitador de água quente. Em combinação com um esquentador, não é recomendável o uso de um bloqueio de água quente.



Manutenção (ver página 54)

As válvulas anti-retorno devem ser verificadas regularmente de acordo com a EN 806-5 segundo os regulamentos nacionais ou regionais (pelo menos uma vez por ano).



Medidas (ver página 43)



Fluxograma (ver página 43)



Peças de substituição (ver página 51)

XXX = Acabamentos
 000 = Cromado
 340 = Brushed Black Chrome
 670 = Matt Black
 800 = Aço Imaculado Ótica

Acessórios especiais

(não incluído no volume de fornecimento)



F12 Crescente #43333000 (ver página 49)



Limpeza (ver página 47)



Funcionamento (ver página 50)

A Hansgrohe recomenda a não utilização do primeiro meio litro de água, de manhã ou após longas paragens, para fins de consumo.



Marca de controlo (ver página 56)

Falha

Causa

Solução

Misturadora perra	- Cartucho defeituoso, calcificado	- Substituir o cartucho
Misturadora a pingar	- Cartucho defeituoso	- Substituir o cartucho
Perde água pela base roscada	- Tubos de ligação não estão completamente enroscados	- Apertar os tubos de ligação à mão
	- O-ring dos tubo de ligação defeituoso	- Trocar o-ring
Temperatura da água quente muito baixa	- O limitador de temperatura está incorrectamente colocado	- Regular o limitador de temperatura



Wskazówki bezpieczeństwa

- △ Aby uniknąć zranień na skutek zgniecenia lub przecięcia, podczas montażu należy nosić rękawice ochronne.
- △ Znaczne różnice ciśnień na doptywach ciepłej i zimnej wody muszą zostać wyrównane.

Wskazówki montażowe

- Przed montażem należy skontrolować produkt pod kątem szkód transportowych. Po montażu nie widać żadnych szkód transportowych ani szkód na powierzchni.
- Przewody i armatura muszą być montowane, płukane i kontrolowane według obowiązujących norm.
- Należy przestrzegać wytycznych instalacyjnych obowiązujących w danym kraju.

Dane techniczne

Ciśnienie robocze:	maks. 1 MPa
Zalecane ciśnienie robocze:	0,1 - 0,5 MPa
Ciśnienie próbne:	1,6 MPa (1 MPa = 10 bary = 147 PSI)
Temperatura wody gorącej:	maks. 60 °C
Dezynfekcja termiczna:	70 °C / 4 min
Produkt przeznaczony wyłącznie do wody pitnej!	

Opis symbolu



Nie stosować silikonów zawierających kwas octowy!



Ustawianie (patrz strona 42)

Ustawianie ogranicznika ciepłej wody. Używanie ogranicznika temperatury wody w połączeniu z przepływowym podgrzewaczem wody nie jest zalecane.



Konserwacja (patrz strona 54)

Zgodnie z normą EN 806-5, krajowymi i miejscowymi przepisami, działanie zabezpieczeń przed przepływem zwrótnym musi być kontrolowane (przynajmniej raz w roku).



Wymiary (patrz strona 43)



Schemat przepływu (patrz strona 43)



Części serwisowe (patrz strona 51)

XXX = Kody kolorów
000 = Chrom
340 = Brushed Black Chrome
670 = Matt Black
800 = Stal Szlachetna

Wyposażenie specjalne

(Nie jest częścią dostawy)



F12 Przedłużka #43333000 (patrz strona 49)



Czyszczenie (patrz strona 47)



Obsługa (patrz strona 50)

Hansgrohe zaleca, by z rana lub po dłuższym czasie niekorzystania, pierwsze pół litra wody nie używać jako wody pitnej.



Znak jakości (patrz strona 56)

Usterka

Przyczyna

Pomoc

Uchwyt armatury pracuje z wysiłkiem	- Uszkodzony wkład, zakamieniony	- Wymiana wkładu
Armatura cieknie	- Uszkodzony wkład	- Wymiana wkładu
Wyciek wody przy mocowaniu od dołu	- Zbyt słabo wkręcone wężyki w korpus - Uszkodzony o-ring przy wężu przyłączeniowym	- Dokręcić wężyki - Wymienić o-ring
Za niska temperatura ciepłej wody	- Niewłaściwe ustawienie ogranicznika ciepłej wody	- Ustawić ogranicznik ciepłej wody





Bezpečnostní pokyny

- △ Pro zabránění řezným zraněním a pohmožděninám je nutné při montáži nosit rukavice.
- △ Je nutné vyrovnat velké rozdíly tlaku mezi přípoji studené a teplé vody.

Pokyny k montáži

- Před montáží je třeba produkt zkontrolovat, zda nebyl při transportu poškozen. Po zabudování nebudou uznány žádné škody způsobené transportem nebo poškození povrchu.
- Vedení a armatura musí být namontovány, propláchnuty a otestovány podle platných norem.
- Je třeba dodržovat montážní pravidla platné v dané zemi.

Technické údaje

Provozní tlak:	max. 1 MPa
Doporučený provozní tlak:	0,1 - 0,5 MPa
Zkušební tlak:	1,6 MPa
	(1 MPa = 10 bar = 147 PSI)
Teplota horké vody:	max. 60 °C
Teplná desinfekce:	70 °C / 4 min

Výrobky Hansgrohe jsou vhodné pro přímý kontakt s pitnou vodou.

Popis symbolů

 Nepoužívat silikon s obsahem kyseliny octové!

Nastavení (viz strana 42)

Nastavení omezovače teplé vody. Ve spojení s průtokovým ohřívačem se použití uzávěru teplé vody nedoporučuje.

Údržba (viz strana 54)

U zpětných ventilů se musí podle EN 806-5 v souladu s národními nebo regionálními předpisy testovat jejich funkčnost (alespoň jednou ročně).

Rozměry (viz strana 43)

Diagram průtoku (viz strana 43)

Servisní díly (viz strana 51)

XXX = Kód povrchové úpravy
 000 = Chrom
 340 = Brushed Black Chrome
 670 = Matt Black
 800 = Nerezová Ocel

Zvláštní příslušenství

(není součástí dodávky)

 F12 prodloužení #43333000 (viz strana 49)

 **Čištění** (viz strana 47)

 **Ovládání** (viz strana 50)

Hansgrohe doporučuje ráno nebo po delších přestávkách nepoužívat prvního půl litru jako pitnou vodu.

 **Zkušební značka** (viz strana 56)

Porucha	Příčina	Odstranění
Armatura jde ztěžka	- Kartuše je vadná, zanesená vodním kamenem	- Kartuši vyměnit
Armatura odkapává	- Kartuše je vadná	- Kartuši vyměnit
výstup vody na upevňovacím násadci	- přípojovací hadice nejsou dostatečně zašroubovány do tělesa - O-kroužek na přípojovací hadici je defektní	- přípojovací hadice utáhnout rukou - vyměnit O-kroužek
Nízká teplota teplé vody	- Špatně nastavená zarážka pro	- Seřadit zarážku pro teplou vodu



Bezpečnostné pokyny

- △ Pri montáži musíte nosiť rukavice, aby ste predišli pomliaždeninám a rezným poraneniam.
- △ Veľké rozdiely v tlaku medzi prípojkami studenej a teplej vody musia byť vyrovnané.

Pokyny pre montáž

- Pred montážou musíte produkt skontrolovať, či nebol počas transportu poškodený. Po zabudovaní nebudú uznané žiadne škody spôsobené transportom alebo poškodenia povrchu.
- Potrubia a vybavenie musia byť namontované, prepláchnuté a vybavené v platnom normami.
- Je potrebné dodržiavať smernice o inštalácii, ktoré sú práve teraz platné v krajinách.

Technické údaje

Prevádzkový tlak: max. 1 MPa
 Doporučený prevádzkový tlak: 0,1 - 0,5 MPa
 Skúšobný tlak: 1,6 MPa
 (1 MPa = 10 bar = 147 PSI)

Teplota teplej vody: max. 60 °C
 Termická dezinfekcia: 70 °C / 4 min

Výrobok je koncipovaný výhradne pre pitnú vodu!

Popis symbolov



Nepoužívať silikón s obsahom kyseliny octovej!



Nastavenie (viď strana 42)

Nastavenie obmedzenia teplej vody. V spojení s prietokovými ohrievačmi sa neodporúča použitie obmedzovača teplej vody.



Údržba (viď strana 54)

Pri spätných ventiloch sa musí podľa EN 806-5 v súlade s národnými alebo regionálnymi predpismi testovať ich funkčnosť (aspoň raz ročne).



Rozmery (viď strana 43)



Diagram prietoku (viď strana 43)



Servisné diely (viď strana 51)

XXX = Farebné označenie
 000 = Chróm
 340 = Brushed Black Chrome
 670 = Matt Black
 800 = Ušľachtilá Oceľ

Zvláštne príslušenstvo

(nie je súčasťou dodávky)



F12 Predĺženie #43333000 (viď strana 49)



Čistenie (viď strana 47)



Obsluha (viď strana 50)

Hansgrohe odporúča ráno a po dlhších dobách odstávky nepoužiť prvého pol litra vody ako pitnú vodu.



Osvedčenie o skúške

(viď strana 56)

Porucha	Príčina	Pomoc
Armatúra "chodí" ťažko	- Kartuša je poškodená, väpenaté usadeniny	- Vymeniť kartušu
Z armatúry kvapká voda	- Kartuša je poškodená	- Vymeniť kartušu
Uhajnanje vode ob prítldilnem nastavku	- Hadice pripojenia nie sú celkom zaskrutkované do základného telesa - Chybný O krúžok na pripojovacej hadici	- Hadice pripojenia dotiahnuť ručne - Vymeniť O krúžok
Nízka teplota teplej vody	- Nesprávne nastavená zarážka na	- Nastavenie zarážky na teplú vodu





安全技巧

- △ 装配时为避免挤压和切割受伤，必须戴上手套。
- △ 冷热水管间过大的压力差必须予以平衡。

安装提示

- 安装前必须检查产品是否受到运输损害。安装后将不认可运输损害或表面损伤。
- 管道和阀门必须根据通用标准进行安装、冲洗和检查。
- 请遵守当地国家现行的安装规定。

技术参数

工作压力: 最大 1 MPa
 推荐工作压力: 0,1 - 0,5 MPa
 测试压强: 1,6 MPa
 (1 MPa = 10 bar = 147 PSI)

热水温度: 最大 60°C
 热力消毒: 70°C / 4 分钟

该产品专为饮用水设计！

符号说明

 请勿使用含有乙酸的硅胶！

 调节 (参见第页 42)

热水温度调节。如果使用即热式喷头，则不建议安装热水阀门。

 保养 (参见第页 54)

单向阀必须在符合国家或当地的法律的情况下按照EN 806-5定期检查 (至少一年一次)。

 大小 (参见第页 43)

 流量示意图 (参见第页 43)

备用零件 (参见第页 51)

XXX = 颜色代码
 000 = 镀铬
 340 = Brushed Black Chrome
 670 = Matt Black
 800 = 不锈钢表面

选装附件 (不在供货范围内)

 F12 加长件 #43333000 (参见第页 49)

 清洗 (参见第页 47)

 操作 (参见第页 50)

汉斯格雅建议，清晨或在水流长时间停滞，前半升水不作饮用水使用。

 检验标记 (参见第页 56)

问题	原因	补救
龙头不灵活	- 阀芯损坏, 结垢	- 更换阀芯
龙头滴水	- 阀芯损坏	- 更换阀芯
水从螺纹底座中流出	- 连接软管没有完全旋入基体 - 连接软管的O形环损坏	- 用手拧紧连接软管 - 更换O形环
热水温度过低	- 温度限制器设置错误	- 设置温度限制器



Указания по технике безопасности

- Во время монтажа следует надеть перчатки во избежание прищемления и порезов.
- донного клапа. Перед установкой смесителя необходимо регулировочными кранами выровнять давление холодной и горячей воды при помощи вентилей регулирующих подачу воды в квартиру.

Указания по монтажу

- Перед монтажом следует проверить изделие на предмет повреждений при перевозке. После монтажа претензии о возмещении ущерба за повреждения при перевозке или повреждения поверхностей не принимаются.
- Трубы и арматура должны быть установлены, промыты и проверены в соответствии с действующими нормами.
- Необходимо соблюдать требования по монтажу, действующие в соответствующих странах.

Технические данные

Рабочее давление: не более. 1 МПа
 Рекомендуемое рабочее давление: 0,1 - 0,5 МПа
 Давление: 1,6 МПа
 (1 МПа = 10 bar = 147 PSI)
 Температура горячей воды: не более. 60 °C
 Термическая дезинфекция: 70 °C / 4 мин
 Изделие предназначено исключительно для питьевой воды!

Описание символов



Не применяйте силикон, содержащий уксусную кислоту.



Подгонка (см. стр. 42)

Регулировка ограничителя горячей воды. В сочетании с проточными нагревателями не рекомендуется использовать блокировку воды.



Техническое обслуживание (см. стр. 54)

Защита обратного тока должна регулярно проверяться (минимум один раз в год) по стандарту EN 806-5 или в соответствии с национальными или региональными нормативами



Размеры (см. стр. 43)



Схема потока (см. стр. 43)



Комплект (см. стр. 51)

XXX = Цветная кодировка
 000 = Хром
 340 = Brushed Black Chrome
 670 = Matt Black
 800 = Сталь

Специальные принадлежности

(не включено в объем поставки!)



F12 Удлинение #43333000 (см. стр. 49)



Очистка (см. стр. 47)



Эксплуатация (см. стр. 50)

Hansgrohe рекомендует по утрам либо после длительного перерыва в использовании не использовать первые поллитра воды для питья.



Знак технического контроля
 (см. стр. 56)

Неисправность	Причина	Устранение неисправности
Арматура работает с усилием	- Картридж неисправен, засорение накипью	- Замените картридж
Арматура протекает	- Картридж неисправен	- Замените картридж
Выход воды у основания крепления	- Шланги подключения не полностью завернуты в корпус	- Затяните шланги подключения вручную
	- Уплотнительное кольцо круглого сечения на соединительном шланге неисправно	- Замените уплотнительное кольцо круглого сечения
Температура горячей воды слишком низкая	- Ограничение горячей воды отрегулировано неправильно	- Отрегулируйте ограничение горячей воды





Turvallisuusohjeet

- △ Asennuksessa on käytettävä käsiineitä puristumien ja viiltojen aiheuttamien tapaturmien estämiseksi.
- △ Suuret paine-erot kylmä- ja kuumavesiliitäntöjen välillä on tasattava.

Asennusohjeet

- Ennen asennusta on tarkastettava tuotteen mahdolliset kuljetusvahingot. Asennuksen jälkeen kuljetus- ja pintavaurioita ei hyväksytä.
- Putket ja hana on asennettava, huuhdeltava ja tarkastettava voimassa olevien standardien mukaisesti.
- Jokaisessa maassa on noudatettava siellä päteviä asennusohjeita.

Tekniset tiedot

Käyttöpain:	maks. 1 MPa
Suosittelu käyttöpain:	0,1 - 0,5 MPa
Koestuspain:	1,6 MPa
	(1 MPa = 10 bar = 147 PSI)
Kuuman veden lämpötila:	maks. 60 °C
Lämpödesinfektio:	70 °C / 4 min

Tuote on suunniteltu käytettäväksi ainoastaan juomaveden kanssa!

Merkin kuvaus



Älä käytä etikkahappopitoista silikonia!

Sääto (katso sivu 42)

Lämpötilan rajoittimen säätäminen. Emme suosittele käyttämään lämpötilan rajoitinta vedenlämmittimen (läpivirtauskuumennin) yhteydessä.

Huolto (katso sivu 54)

Vastaventtiilien toiminta on tarkastettava säännöllisesti paikallisten ja kansallisten määräysten mukaisesti (EN 806-5, vähintään kerran vuodessa).



Mitat (katso sivu 43)



Virtausdiagrammi (katso sivu 43)



Varaosat (katso sivu 51)

XXX = Värikoodaus
000 = Kromi
340 = Brushed Black Chrome
670 = Matt Black
800 = Inox-Optinen

Erityisvaruste (ei kuulu toimitukseen)



F12 Pidennys #43333000 (katso sivu 49)



Puhdistus (katso sivu 47)



Käyttö (katso sivu 50)

Hansgrohe suosittelee, että ensimmäistä puolta litraa ei käytetä juomavetenä aamuisin eikä silloin, kun laitetta ei ole käytetty pitkään aikaan.



Koestusmerkki (katso sivu 56)

Häiriö

Syy

Toimenpide

Hana on raskaskäyttöinen	- Patruuna rikki, kalkkikerrostumia	- Vaihda patruuna
Hanasta tippuu vettä	- Patruuna rikki	- Vaihda patruuna
Vettä valuu kiinnityskauluksesta	- Liitosletkut eivät ole kierretty kiinni perusrunkoon pohjaan asti	- Kierrä liitosletkut kiinni käsikireyteen
	- Liitosletkun O-renkas on rikki	- Vaihda O-renkas
Lämminveden lämpötila liian alhainen	- Lämminveden rajoitin väärin säädetty	- Säädä lämminveden rajoitin



Säkerhetsanvisningar

- △ Handskar ska bäras under monteringsarbetet så att man kan undvika kläm- och skärskador.
- △ Stora tryckskillnader mellan anslutningarna för varmt och kallt vatten måste utjämnas.

Monteringsanvisningar

- Det måste undersökas om produkten har transportskador innan den monteras. Efter monteringen accepteras inga transport- eller ytskiktsskador.
- Ledningarna och blandaren måste monteras, spolas igenom och kontrolleras enligt de gällande normerna.
- De installationsriktlinjer som gäller i länderna ska följas.

Tekniska data

Driftstryck: max. 1 MPa
 Rek. driftstryck: 0,1 - 0,5 MPa
 Tryck vid provtryckning: 1,6 MPa

(1 MPa = 10 bar = 147 PSI)

Varmvattentemperatur: max. 60 °C
 Termisk desinfektion: 70 °C / 4 min

Produkten är enbart avsedd för dricksvatten!

Symbolförklaring



Använd inte silikon som innehåller ättiksyra!



Justering (se sidan 42)

Ställa in varmvattenregleringen. Tillsammans med varmvattenberedare rekommenderas inte en varmvattenspär.



Skötsel (se sidan 54)

Backventilens funktion måste kontrolleras regelbundet enligt nationella eller regionala bestämmelser i enlighet med EN 806-5 (minst en gång per år).

Störning	Orsak	Åtgärd
Blandare är trög	- Patron defekt, förkalkad	- Byt ut patron
Blandare droppar	- Patron defekt	- Byt ut patron
Vatten kommer ut vid monteringsstaget	- Anslutningsslangar inte helt inskruvade i grundkonstruktionen	- Drag fast anslutningsslangar för hand.
	- O-ring på anslutningsslang defekt	- Byt ut O-ring
Varmvattentemperaturen är för låg	- Varmvattenreglering felaktigt inställd	- Ställ in varmvattenreglering



Måtten (se sidan 43)



Flödesschema (se sidan 43)



Reservdelar (se sidan 51)

XXX = Färgkodning
 000 = Krom
 340 = Brushed Black Chrome
 670 = Matt Black
 800 = Rostfri-Optik

Specialtillbehör (medföljer ej leveransen)



F12 Förlängning #43333000 (se sidan 49)



Rengöring (se sidan 47)



Hantering (se sidan 50)

Hansgrohe rekommenderar att den första halvlitern inte används som dricksvatten på morgonen eller efter längre perioder utan användning.



Testsgill (se sidan 56)

**Saugumo technikos nurodymai**

- △ Apsaugai nuo užspaudimo ir įsijpavimo montavimo metu mūvėkite pirštines.
- △ Turi būti išlyginti šalto ir karšto slėgio nelygumai.

Montavimo instrukcija

- Prieš montuojant būtina patikrinti, ar gaminys nebuvo pažeistas transportavimo metu. Sumontavus pretenzijos dėl transportavimo ir paviršiaus pažeidimų nepriimamos.
- Vamzdžiai ir sujungimai turi būti montuojami, plaunami ir tikrinami pagal galiojančias normas.
- Laikykites atitinkamoje šalyje galiojančių direktyvų dėl įrengimo.

Techniniai duomenys

Darbinis slėgis: ne daugiau kaip 1 MPa
 Rekomenduojamas slėgis: 0,1 - 0,5 MPa
 Bandomasis slėgis: 1,6 MPa
 (1 MPa = 10 barų = 147 PSI)

Karšto vandens temperatūra: ne daugiau kaip 60°C
 Terminis dezinfekavimas: 70°C / 4 min

Produktas skirtas tik geriamajam vandeniui!

Simbolio aprašymas

Nenaudokite silikono, kurio sudėtyje yra acto rūgšties!

**Reguliavimas** (žr. psl. 42)

Karšto vandens ribojimas. Kartu su cirkuliaciniais šildytuvais nerekomenduojama naudoti karšto vandens blokavimo įtaisų.

**Techninis aptarnavimas**

(žr. psl. 54)

Atbulinio vožtuvo apsauga privalo būti tikrinama reguliariai (mažiausiai kartą per metus) pagal EN 806-5 arba pagal galiojančias nacionalines arba regionines normas.

**Išmatavimai** (žr. psl. 43)**Pralaidumo diagrama** (žr. psl. 43)**Atsarginės dalys** (žr. psl. 51)

XXX = Spalvos
 000 = Chrom
 340 = Brushed Black Chrome
 670 = Matt Black
 800 = Plienas

Specialūs priedai (nėra pridedama)

F12 Ilgiklis #43333000 (žr. psl. 49)

**Valymas** (žr. psl. 47)**Eksplotacija** (žr. psl. 50)

Naudojant po ilgesnės pertraukos, „Hansgrohe“ rekomenduoja pirmo pusės litro vandens nevartoti kaip geriamojo.

**Bandymo pažyma** (žr. psl. 56)**Gedimas****Priežastis****Priemonė**

Sunkiai sukiojama rankenėlė	- Kasetė pažeista, užkalkėjusi	- Pakeisti kasetę
Maišytuvus praleidžia vandenį	- Kasetė pažeista	- Pakeisti kasetę
Prateka vanduo per tvirtinimo kotą	- Prijungimo žarnos nepilnai įsuktos į korpusą	- Prijungimo žarnas prisukti ranka
	- Pajungimo žarnos tarpinė pažeista	- tarpinę pakeisti
Per maža karšto vandens temperatūra	- Neteisingai nustatytas karšto vandens ribotuvas	- Nustatyti karšto vandens ribotuvas



Sigurnosne upute

- ⚠ Prilikom montaže se radi sprječavanja prignječenja i posjekotina moraju nositi rukavice.
- ⚠ Velika razlika u pritisku između vruće i hladne vode mora biti izbalansirana.

Upute za montažu

- Prije montaže mora se provjeriti je li proizvod oštećen prilikom transporta. Nakon ugradnje se ne priznaju nikakve reklamacije koje se odnose na površinska i transportna oštećenja.
- Cijevi i armatura moraju biti postavljeni, isprani i testirani prema važećim normama.
- Obvezno se moraju uvažiti propisi o instalacijama koji vrijede u dotičnoj zemlji.

Tehnički podatci

Najveći dopušteni tlak: tlak 1 MPa
 Preporučeni tlak: 0,1 - 0,5 MPa
 Probni tlak: 1,6 MPa
 (1 MPa = 10 bar = 147 PSI)

Temperatura vruće vode: tlak 60°C
 Termička dezinfekcija: 70°C / 4 min

Proizvod je koncipiran isključivo za pitku vodu!

Opis simbola



Nemojte koristiti silikon koji sadrži octenu kiselinu!



Regulacija (pogledaj stranicu 42)

Namještanje limitera tople vode. U kombinaciji s protočnim bojlerima nije preporučljiva primjena sustava za blokiranje dotoka tople vode.



Održavanje (pogledaj stranicu 54)

Ispravnost nepovratnog ventila mora se redovito provjeravati prema standardu EN 806-5 i u skladu sa važećim propisima (najmanje jednom godišnje).



Mjere (pogledaj stranicu 43)



Dijagram protoka

(pogledaj stranicu 43)



Rezervni djelovi

(pogledaj stranicu 51)

XXX = Boje
 000 = Krom
 340 = Brushed Black Chrome
 670 = Matt Black
 800 = Plemeniti Čelik

Posebni pribor (Nije sadržano u isporuci!)



F12 Produljenje
 #43333000 (pogledaj stranicu 49)



Čišćenje (pogledaj stranicu 47)



Upotreba (pogledaj stranicu 50)

Hansgrohe preporuča da ujutro ili nakon duljeg nekorištenja prvih 1/2 litre vode ne upotrebljavate za piće.



Oznaka testiranja

(pogledaj stranicu 56)

Greška	Uzrok	Otklanjanje
Ručica se zaglavila	- Neispravan uložak Taloženje kamenca	- Zamijenite uložak
Slavina kaplje	- Neispravan uložak	- Zamijenite uložak
Voda izlazi na dijelu gdje je slavina učvršćena	- Priključna crijeva nisu potpuno učvršćena na tijelo - O-prsteni priključnih crijeva su neispravni	- Priključna crijeva učvrstite rukom - Zamijenite O-prsten
Preiska temperatura tople vode	- Limiter vruće vode nije dobro podešen	- Podesite limiter vruće vode





Güvenlik uyarıları

- △ Montaj esnasında ezilme ve kesilme gibi yaralanmaları önlemek için eldiven kullanılmalıdır.
- △ Sıcak ve soğuk su bağlantıları arasında büyük basınç farklılıkları varsa, bu basınç farklılıklarının dengelenmesi gerekir.

Montaj açıklamaları

- Montaj işleminden önce ürün nakliye hasarları yönünden kontrol edilmelidir. Montaj işleminden sonra nakliye veya yüzey hasarları için sorumluluk üstlenilmemektedir.
- Boruların ve armatürün montajı, yıkanması ve kontrolü geçerli normlara göre yapılmalıdır.
- Ülkelerde geçerli kurulum yönetmeliklerine riayet edilmelidir.

Teknik bilgiler

İşletme basıncı: azami 1 MPa
Tavsiye edilen işletme basıncı: 0,1 - 0,5 MPa
Kontrol basıncı: 1,6 MPa
(1 MPa = 10 bar = 147 PSI)

Sıcak su sıcaklığı: azami 60°C
Termik dezenfeksiyon: 70°C / 4 dak
Ürün sadece şebeke suyu için tasarlanmıştır!

Simge açıklaması

 Asetik asit içeren silikon kullanmayın!

 **Ayarlama** (bakınız sayfa 42)

Sıcak su sınırlamasının ayarlanması. Sıcak su kilidinin sürekli ısıtıcıyla kullanılması tavsiye edilmez.

 **Bakım** (bakınız sayfa 54)

EN 806-5 ve ulusal standartlar doğrultusunda Çek valfler düzenli olarak kontrol edilmelidir. (en az yılda bir kez)

 **Ölçüleri** (bakınız sayfa 43)

 **Akış diyagramı** (bakınız sayfa 43)

 **Yedek Parçalar** (bakınız sayfa 51)

XXX = Renkler
000 = Krom
340 = Brushed Black Chrome
670 = Matt Black
800 = Paslanmaz Çelik-Optik

Özel aksesuarlar

(Teslimat kapsamına dahil değildir)

 F12 Uzatma #43333000 (bakınız sayfa 49)

 **Temizleme** (bakınız sayfa 47)

 **Kullanımı** (bakınız sayfa 50)

Hansgrohe sabahları uzun durgunluk süresi sonrasında ilk yarım litre suyun içme suyu olarak kullanılmamasını önerir.

 **Kontrol işareti** (bakınız sayfa 56)

arıza	sebebi	yardım
Batarya kullanımı ağırlaşıyor	- Kartuş Bozulmuş ve kireçlenmiş olabilir	- Kartuşu değiştirin
Batarya su damlatıyor	- Kartuş bozuk olabilir	- Kartuşu değiştirin
Sabitleme kutusundan su çıkışı	- Bağlantı hortumları ana gövdeye tamamen vidalanmamış - Bağlantı hortumundaki O-ring arızalı	- Bağlantı hortumlarını elinizle sıkın - O-ringi değiştirin
Sıcak suyun derecesi çok düşük	- Isı limitleyici düzgün çalışmıyor	- Isı limitleyiciyi yeniden ayarlayın



Instrucțiuni de siguranță

- ⚠ La montare utilizați mănuși pentru evitarea contuziunilor și tăierii mâinilor.
- ⚠ Diferențele de presiune mari între alimentarea cu apă rece și apă caldă trebuie echilibrate.

Instrucțiuni de montare

- Înainte de instalare verificați, dacă produsul prezintă deteriorări de transport. După instalare garanția nu acoperă deteriorările de transport și cele de suprafață.
- Conductele și bateriile trebuie montate, spălate și verificate conform normelor în vigoare.
- Respectați reglementările referitoare la instalare valabile în țara respectivă.

Date tehnice

Presiune de funcționare:	max. 1 MPa
Presiune de funcționare recomandată:	0,1 - 0,5 MPa
Presiune de verificare:	1,6 MPa
	(1 MPa = 10 bar = 147 PSI)
Temperatura apei calde:	max. 60 °C
Dezinfecție termică:	70 °C / 4 min

Produsul este destinat exclusiv pentru apă potabilă.

Descrierea simbolurilor



Nu utilizați silicon cu conținut de acid acetic!



Reglare (vezi pag. 42)

Reglarea limitatorului de apă caldă. Nu se recomandă folosirea unui limitator de apă caldă în combinație cu un boiler instant.



Întreținere (vezi pag. 54)

Supapele antiretur trebuie verificate regulat conform EN 806-5 și standardele naționale sau regionale (cel puțin o dată pe an).



Dimensiuni (vezi pag. 43)



Diagrama de debit (vezi pag. 43)



Piese de schimb (vezi pag. 51)

XXX = Coduri de culori
 000 = Crom
 340 = Brushed Black Chrome
 670 = Matt Black
 800 = Otel Inox

Accesorii opționale

(nu este inclus în setul livrat)



F12 Prelungitor #43333000 (vezi pag. 49)



Curățare (vezi pag. 47)



Utilizare (vezi pag. 50)

Hansgrohe vă recomandă, ca dimineața sau după perioade mai lungi de pauză să nu folosiți prima jumătate de litru de apă pentru băut.



Certificat de testare (vezi pag. 56)

Deranjament	Cauza	Măsuri de remediere
Bateria se mișcă dificil	- Cartuș defect din cauza depunerilor de calcar	- Schimbați cartușul.
Bateria picură	- Cartuș defect	- Schimbați cartușul.
Scurgere de apă la șaftul de fixare.	- Furtunurile de racordare nu sunt bine înșurubate în corpul bateriei.	- Strângeți cu mâna furtunurile de racordare.
	- Inelul O de la furtunul de racord defect	- Schimbați inelul O.
Temperatura apei calde este prea mică	- Limitarea temperaturii apei calde setată incorect.	- Setați limitarea temperaturii apei calde.





Υποδειξεις ασφαλείας

- △ Για να αποφύγετε τραυματισμούς κατά τη συναρμολόγηση πρέπει να φοράτε γάντια.
- △ Οι διαφορές της πίεσης μεταξύ της σύνδεσης κρύου και ζεστού νερού θα πρέπει να αντισταθμίζονται.

Οδηγίες συναρμολόγησης

- Πριν τη συναρμολόγηση πρέπει να εξεταστεί το προϊόν για ζημιές μεταφοράς. Μετά την εγκατάσταση δεν αναγνωρίζονται ζημιές από τη μεταφορά ή επιφανειακές ζημιές.
- Οι σωλήνες και η μπαταρία πρέπει να τοποθετηθούν σύμφωνα με τα ισχύοντα πρότυπα, να τεθούν υπό πίεση και να δοκιμαστούν.
- Θα πρέπει να τηρούνται οι οδηγίες εγκατάστασης που ισχύουν σε κάθε κράτος.

Τεχνικά Χαρακτηριστικά

Λειτουργία πίεσης: έως 1 MPa
 Συνιστώμενη λειτουργία πίεσης: 0,1 - 0,5 MPa
 Πίεση ελέγχου: 1,6 MPa
 (1 MPa = 10 bar = 147 PSI)

Θερμοκρασία ζεστού νερού: έως 60 °C
 Θερμική απολύμανση: 70 °C / 4 min

Το προϊόν έχει σχεδιαστεί αποκλειστικά για πόσιμο νερό!.

Περιγραφή συμβόλων

 Μην χρησιμοποιείτε σιλικόνη που περιέχει οξικό οξύ!

Ρύθμιση (βλ. Σελίδα 42)

Ρύθμιση του δοσομετρητή ζεστού νερού. Δεν συνιστάται η διάταξη φραγής ζεστού νερού σε συνδυασμό με ταχυθερμοσίφωνα.

Συντήρηση (βλ. Σελίδα 54)

Οι βαλβίδες αντεπιστροφής πρέπει να ελέγχονται τακτικά ως προς τη λειτουργία τους, σύμφωνα με το πρότυπο EN 806-5, σε σχέση με τους ισχύοντες εθνικούς ή τοπικούς κανόνες (το ελάχιστο μια φορά το χρόνο) .

Διαστάσεις (βλ. Σελίδα 43)

Διάγραμμα ροής (βλ. Σελίδα 43)

Ανταλλακτικά (βλ. Σελίδα 51)

XXX = Χρώματα
 000 = Επιχρωμωμένο
 340 = Brushed Black Chrome
 670 = Matt Black
 800 = Οπτική Ανοξειδωτου Χάλυβα

Ειδικά αξεσουάρ (δεν περιλαμβάνεται στον παραδοτέο εξοπλισμό)

 F12 Σωλήνας επιμήκυνσης #43333000 (βλ. Σελίδα 49)

 Καθαρισμός (βλ. Σελίδα 47)

 Χειρισμός (βλ. Σελίδα 50)

Η Hansgrohe συνιστά το πρωί ή μετά από μεγάλα χρονικά διαστήματα αχρησίας να μην χρησιμοποιείτε το πρώτο μισό λίτρο νερό σαν πόσιμο.

 Σήμα ελέγχου (βλ. Σελίδα 56)

Βλάβη	Αιτία	Διόρθωση
Σκληρή μπαταρία (μείκτης)	- Ελαττωματικό φυσίγγιο, άλατα	- Αλλαγή φυσιγγίου
Η μπαταρία στάζει	- Ελαττωματικό φυσίγγιο	- Αλλαγή φυσιγγίου
Διαρροή νερού στον άξονα στερέωσης	- Οι σωλήνες σύνδεσης δεν είναι πλήρως βιδωμένοι στο βασικό κορμό	- Σφίξτε τους σωλήνες σύνδεσης με το χέρι
	- Ο στρογγυλός δακτύλιος στο σωλήνα σύνδεσης είναι ελαττωματικός	- Αλλάξτε το στρογγυλό δακτύλιο
Χαμηλή θερμοκρασία ζεστού νερού	- Λάθος ρύθμιση της περιοριστικής διάταξης ζεστού νερού	- Ρυθμίστε την περιοριστική διάταξη του ζεστού νερού



Varnostna opozorila

- ⚠ Pri montaži je treba nositi rokavice, da se preprečijo poškodbe zaradi zmečkanja ali urezov.
- ⚠ Velike razlike v tlaku med priključkom za mrzlo in priključkom za toplo vodo je potrebno izravnati.

Navodila za montažo

- Pred montažo je treba izdelek preveriti glede morebitnih transportnih poškodb. Po vgradnji transportne ali površinske poškodbe ne bodo več priznane.
- Cevi in armaturo je treba montirati, izprati in preveriti po veljavnih standardih.
- Upoštevati je treba pravilnike o inštalacijah, ki veljajo v posamezni državi.

Tehnični podatki

Delovni tlak:	maks. 1 MPa
Priporočeni delovni tlak:	0,1 - 0,5 MPa
Preskusni tlak:	1,6 MPa
	(1 MPa = 10 bar = 147 PSI)
Temperatura tople vode:	maks. 60 °C
Termična dezinfekcija:	70 °C / 4 min
Proizvod je zasnovan izključno za sanitarno vodo!	

Opis simbola



Ne smete uporabiti silikona, ki vsebuje ocetno kislino!



Justiranje (glejte stran 42)

Nastavitev omejevalnika tople vode. V povezavi s pretočnimi grelniki uporaba zapore tople vode ni priporočljiva.



Vzdrževanje (glejte stran 54)

Delovanje protipovratnega ventila je potrebno v skladu z EN 806-5 in skladno z državnimi in regionalnimi določili redno testirati (najmanj enkrat letno).



Mere (glejte stran 43)



Diagram pretoka (glejte stran 43)



Rezervni deli (glejte stran 51)

- XXX = Barve
- 000 = Krom
- 340 = Brushed Black Chrome
- 670 = Matt Black
- 800 = Videz Legiranega Jekla

Poseben pribor (Ni vključeno)



F12 Podaljšek #43333000 (glejte stran 49)



Čiščenje (glejte stran 47)



Upravljanje (glejte stran 50)

Hansgrohe priporoča, da zjutraj ali po daljšem času stagnacije prvega pol litra vode ne uporabite kot pitno vodo.



Preskusni znak (glejte stran 56)

Napaka	Vzrok	Pomoč
Težko premikanje armature	- Pokvarjen vložek, poapneno	- Zamenjajte vložek
Iz armature kaplja	- Pokvarjen vložek	- Zamenjajte vložek
Uhajanje vode ob pritrdilnem nastavku	- Priključne cevi niso popolnoma privijačene v osnovno ogrodje	- Ročno zatisnite priključne cevi
	- Obročna tesnila priključnih gibkih cevi so pokvarjena	- Zamenjajte obročno tesnilo
Pre nizka temperatura tople vode	- Omejevalnik tople vode ni pravilno nastavljen	- Nastavite omejevalnik tople vode





Ohutusjuhised

- △ Kandke paigaldamisel muljumis- ja löikevigastuste vältimiseks kindaid.
- △ Kui külma ja kuuma vee ühenduste surve on väga erinev, tuleb need tasakaalustada.

Paigaldamisjuhised

- Enne paigaldamist tuleb toodet kontrollida transpordikahjustuste osas. Pärast paigaldamist ei tunnustata enam transpordi- või pinnakahjustuste kaebuseid.
- Voolikute ja segisti paigaldamisel, loputamisel ja kontrollimisel tuleb lähtuda kehtivatest normatiividest
- Vastavas riigis kehtivaid paigalduseeskirju tuleb järgida.

Tehnilised andmed

Töörõhk	maks. 1 MPa
Soovitatav töörõhk:	0,1 - 0,5 MPa
Kontrollsurve:	1,6 MPa (1 MPa = 10 baari = 147 PSI)
Kuuma vee temperatuur:	maks. 60°C
Terminline desinfitatsioon:	70°C / 4 min

Toode on ette nähtud eranditult joogivee jaoks!

Sümbolite kirjeldus



Ärge kasutage äädikhapet sisaldavat silikooni!



Reguleerimine (vt lk 42)

Sooja vee piirangu seadistamine. Ühenduses boileritega ei ole sooja vee blokeeringu soovitatav.



Hooldus (vt lk 54)

Tagasilöögiklappide toimimist tuleb kooskõlas riiklike ja regionaalsete määrustega regulaarselt kontrollida vastavalt standardile EN 806-5 (vähemalt kord aastas).



Mõõtude (vt lk 43)

Rike	Põhjus	Lahendus
Segisti käib raskelt	- Tööelement on katkine, lubjastunud	- Vahetage tööelement
Segisti tilgub	- Tööelement on katkine	- Vahetage tööelement
Veeleke kinnituse juures	- Ühendusvoolikud ei ole korralikult põhikorpuse külge kruvitud	- Kruvige ühendusvoolikud käega kinni
	- Ühendusvoolikute O-rõngastihendid katki	- Vahetage O-rõngastihend
Sooja vee temperatuur liiga madal	- Kuuma vee piirang valesti seatud	- Seadke kuuma vee piirang



Läbivooludiagramm (vt lk 43)



Varuosad (vt lk 51)

- XXX = Värvid
- 000 = Kroom
- 340 = Brushed Black Chrome
- 670 = Matt Black
- 800 = Roostevaba Optik

Spetsiaalne lisavarustus

(ei sisaldu komplektis)



F12 Pikendus #43333000 (vt lk 49)



Puhastamine (vt lk 47)



Kasutamine (vt lk 50)

Hansgrohe soovib mitte kasutada esimest poolt liitrit hommikuti või pärast pikemat seisakuaega joogiveena.



Kontrollsertifikaat (vt lk 56)





Drošības norādes

- △ Montāžas laikā, lai izvairītos no saspiedumiem un iegriezumiem, nepieciešams nēsāt cimdus.
- △ Jāizlīdzina spiediena atšķirības starp aukstā un karstā ūdens pievadiem.

Norādījumi montāžai

- Pirms montāžas nepieciešams pārbaudīt, vai produktam transportēšanas laikā nav radušies bojājumi. Pēc iebūvēšanas bojājumi, kas radušies transportēšanas laikā, vai virsmas bojājumi netiek atzīti.
- Caurulvadi un armatūra ir jāuzstāda, jāizskalo un jāpārbauda saskaņā ar spēkā esošajiem standartiem.
- Jāievēro attiecīgās valstīs spēkā esošās montāžas prasības.

Tehniskie dati

Darba spiediens: maks. 1 MPa
 Ieteicamais darba spiediens: 0,1 - 0,5 MPa
 Pārbaudes spiediens: 1,6 MPa
 (1 MPa = 10 bar = 147 PSI)

Karstā ūdens temperatūra: maks. 60°C
 Termiskā dezinfekcija: 70°C / 4 min

Izstrādājums ir paredzēts tikai dzeramajam ūdenim!

Simbolu nozīme



Neizmantojot silikonu, kas satur etiķskābi!



Ieregulēšana (skat. lpp. 42)

Karsta ūdens ierobežotāja regulēšana. Kopā ar caurteces sildītājiem nav ieteicams izmantot ūdens bloķētāju.



Apkope (skat. lpp. 54)

Regulāri jāpārbauda pretvārsta funkcija saskaņā ar EN 806-5 saistībā ar nacionālajiem vai vietējiem noteikumiem (vismaz vienreiz gadā).



Izmērus (skat. lpp. 43)



Caurplūdes diagramma

(skat. lpp. 43)



Rezerves daļas (skat. lpp. 51)

XXX = Krāsu kodi
 000 = Hroma
 340 = Brushed Black Chrome
 670 = Matt Black
 800 = Tērauda

Speciāli aksesuāri

(komplektā netiek piegādāts)



F12 Pagarinājums #43333000 (skat. lpp. 49)



Tīrīšana (skat. lpp. 47)



Lietošana (skat. lpp. 50)

Hansgrohe iesaka no rīta vai pēc ilgākiem pārtraukumiem nelietot pirmo puslitru ūdens dzeršanai.



Pārbaudes zīme (skat. lpp. 56)

Traucējums	Iemesls	Bojājumu novēršana
Jaucējkrāns smagi grozāms	- Bojāta kartuša, aizkaļķojusies	- Nomainīt kartušu
Jaucējkrāns pil	- Bojāta kartuša	- Nomainīt kartušu
Ūdens noplūde pie nostiprinājuma	- Pieslēguma šļūtenes nav līdz galam ieskrūvētas pamatelementā	- Pieslēguma šļūtenes ar roku pievilkt stingrāk
	- Bojāti pieslēguma šļūtenju O-gredzeni	- Nomainīt O-gredzenu
Pārāk zema ūdens temperatūra	- Nepareizi noregulāta karstā ūdens bloķēšana	- Noregulēt karstā ūdens ierobežošanu





Sigurnosne napomene

- △ Prilikom montaže se radi sprečavanja prignječenja i posekotina moraju nositi rukavice.
- △ Velika razlika u pritisku između vruće i hladne vode mora biti izbalansirana.

Instrukcije za montažu

- Pre montaže se mora proveriti da li je proizvod oštećen pri transportu. Nakon ugradnje se ne priznaju nikakve reklamacije koje se odnose na površinska i transportna oštećenja.
- Vodovi i armatura moraju biti postavljeni, isprani i testirani prema važećim normama.
- Treba se pridržavati propisa koji u određenim zemljama važe za instalacije.

Tehnički podaci

Radni pritisak:	maks. 1 MPa
Preporučeni radni pritisak:	0,1 - 0,5 MPa
Probni pritisak:	1,6 MPa (1 MPa = 10 bar = 147 PSI)
Temperatura vruće vode:	maks. 60 °C
Termička dezinfekcija:	70 °C / 4 min

Proizvod je koncipiran isključivo za pijaću vodu!

Opis simbola



Nemojte koristiti silikon koji sadrži sirćetnu kiselinu!



Podešavanje (vidi stranu 42)

Podešavanje ograničivača tople vode. U kombinaciji sa protočnim bojlerima ne preporučuje se primena sistema za blokiranje dotoka tople vode.



Održavanje (vidi stranu 54)

Ispravno funkcionisanje nepovratnog ventila se mora redovno proveravati prema standardu EN 806-5 i u

skladu s važećim nacionalnim ili regionalnim propisima (najmanje jednom godišnje).



Mere (vidi stranu 43)



Dijagram protoka (vidi stranu 43)



Rezervni delovi (vidi stranu 51)

XXX = Oznake boja
 000 = Hrom
 340 = Brushed Black Chrome
 670 = Matt Black
 800 = Dezen Plemeniti Čelik

Poseban pribor (Nije sadržano u isporuci)



F12 Produžetak #43333000 (vidi stranu 49)



Čišćenje (vidi stranu 47)



Rukovanje (vidi stranu 50)

Hansgrohe preporučuje da ujutru ili nakon dužeg nekorišćenja prvih pola litre vode ne koristite za piće.



Ispitni znak (vidi stranu 56)

Smetnja	Uzrok	Pomoć
Ručica se zaglavila	- Neispravna kartuša, nataloženi kamenac	- Zamenite kartušu
Slavina kaplje	- Neispravna kartuša	- Zamenite kartušu
Voda izlazi na delu gde je slavina učvršćena	- Priključna creva nisu potpuno učvršćena na telo - O prstenovi priključnih creva su neispravni	- Priključna creva učvrstite rukom - Zamenite O prsten
Previsoka temperatura tople vode	- Ograničavač vruće vode nije dobro podešen	- Podesite ograničavač vruće vode



Sikkerhetshenvisninger

- △ Bruk hansker under montasjen for å unngå klem- og kuttskader.
- △ Store trykkdifferanser mellom kaldt- og varmtvannstilkoblinger skal utlignes.

Montagehenvisninger

- Før montasjen skal produktet sjekkes for transportskader. Etter monteringen aksepteres ikke noen transport- eller overflateskader.
- Ledningene og armaturen skal monteres, spyles og sjekkes iht. de gyldige normer.
- Gjeldende retningslinjer for rørleggerarbeid i de enkelte land skal følges.

Tekniske data

Driftstrykk	maks. 1 MPa
Anbefalt driftstrykk:	0,1 - 0,5 MPa
Prøvetrykk	1,6 MPa (1 MPa = 10 bar = 147 PSI)
Varmtvannstemperatur	maks. 60°C
Termisk desinfisering:	70°C / 4 min

Produktet er utelukkende designet for drikkevann!

Symbolbeskrivelse



Ikke bruk silikon som inneholder eddiksyre!



Justering (se side 42)

Innstilling av varmtvannsbegrensning. I forbindelse med gjennomstrømningsvarmere er det ikke anbefalt å bruke en varmtvannspërre.



Vedlikehold (se side 54)

Funksjonen til returløpsspærren skal iht. EN 806-5 og i samsvar med de nasjonale og lokale forskrifter sjekkes regelmessig (minst en gang i året).



Mål (se side 43)

Gjennomstrømningsdiagram (se side 43)



Service-deler (se side 51)

XXX = Fargekode
 000 = Krom
 340 = Brushed Black Chrome
 670 = Matt Black
 800 = Rustfritt Stål Optikk

Ekstratilbehør (ikke med i leveransen)



F12 Forlengelse #43333000 (se side 49)



Rengjøring (se side 47)



Betjening (se side 50)

Om morgen og etter lengre stagnasjonstider anbefaler Hansgrohe å ikke bruke den første halvliteren som drikkevann.



Prøvemerket (se side 56)

Feil	Årsak	Feilrettelse
Armatyr ikke lett bevegelig	- Kartusj defekt, forkalkning	- Kartusj byttes
Armatyr drypper	- Kartusj defekt	- Kartusj byttes
Vannlekkasje på festeskapt	- Tilkoblingsslang er ikke skrudd helt inn i baseelement	- Tilkoblingsslang trekkes fast fra hånd
	- O-ring på tilkoblingsslangen defekt	- O-ring byttes
For lav varmtvannstemperatur	- Varmtvannsbegrensning er feil innstilt	- Varmtvannsbegrensning innstilles





Указания за безопасност

- △ При монтажа трябва да се носят ръкавици, за да се избегнат наранявания поради притискане или порязване.
- △ Големите разлики в налягането между изводите за студената и топлата вода трябва да се изравняват.

Указания за монтаж

- Преди монтажа продуктът трябва да се провери за транспортни щети. След монтажа не се признават транспортни или повърхностни щети.
- Тръбопроводите и арматурата трябва да се монтира, промият и проверят в съответствие с валидните норми.
- Трябва да бъдат спазвани валидните в съответните страни предписания за инсталиране.

Технически данни

Работно налягане: макс. 1 МПа
 Препоръчително работно налягане: 0,1 - 0,5 МПа
 Контролно налягане: 1,6 МПа
 (1 МПа = 10 bar = 147 PSI)
 Температура на горещата вода: макс. 60°С
 Термична дезинфекция: 70°С / 4 мин
 Продуктът е разработен само за питейна вода!

Описание на символите



Не използвайте силикон, съдържащ оцветна киселина!



Юстиране (вижте стр. 42)

Настройка на ограничителя за топлата вода. Във връзка с проточни нагреватели не се препоръчва блокировка за топлата вода



Поддръжка (вижте стр. 54)

Съгласно EN 806-5 функционирането на приспособленията за предотвратяване на обратния поток трябва редовно да се проверява в съответствие с националните или регионални изисквания (поне веднъж годишно).



Размери (вижте стр. 43)



Диаграма на потока (вижте стр. 43)



Сервизни части (вижте стр. 51)

XXX = Цветово кодиране
 000 = Хром
 340 = Brushed Black Chrome
 670 = Matt Black
 800 = Оптика На Благородна Стомана

Специални принадлежности

(не се съдържа в обема на доставка)



F12 Удължител #43333000 (вижте стр. 49)



Почистване (вижте стр. 47)



Обслужване (вижте стр. 50)

Hansgrohe препоръчва, сутрин и след по-продължително спиране първият половин литър да не се използва като питейна вода.



Контролен знак (вижте стр. 56)

Неизправност	Причина	Помощ
Трудно подвижна арматура	- Дефектна гилза, покрита с варовик	- Сменете гилзата
Арматурата капе	- Дефектна гилза	- Сменете гилзата
Избиване на вода от закрепващата шийка	- Свързващите маркучи не са напълно завинтени в основното тяло - Дефектен О-образен пръстен на свързващия маркуч	- Затегнете на ръка свързващите маркучи - Смяна на О-образен пръстен
Твърде ниска температура на водата	- Ограничението за топлата вода е грушно настроено	- Настройте ограничението за топлата вода





Shqip



Udhëzime sigurie

- △ Për të evituar lëndimet e pickimeve ose të prerjeve gjatë procesit të montimit duhet që të vishni doreza.
- △ Ndryshimet e mëdha të presionit mes lidhjeve të ujit të ftohtë dhe atij të ngrohtë duhen ekuilibruar.

Udhëzime për montimin

- Përpara montimit duhet që produkti të kontrollohet për dëmtime nga transporti. Pas instalimit nuk do të njihet asnjë dëmtim nga transporti ose dëmtim i sipërfaqes.
- Tubacionet dhe rubinetet duhet që të montohen, të shpëlahen dhe të kontrollohen sipas standardeve në fuqi
- Duhet të respektohen linjat udhëzuese të instalimit, të vlefshme për vendet respektive.

Të dhëna teknike

Presioni gjatë punës maks. 1 MPa
 Presioni i rekomanduar: 0,1 - 0,5 MPa
 Presioni për provë: 1,6 MPa
 (1 MPa = 10 bar = 147 PSI)

Temperatura e ujit të ngrohtë maks. 60 °C
 Dezinfektim Termik: 70 °C / 4 min

Produkti është projektuar ekskluzivisht për ujë të pijshëm!

Përshkrimi i simbolit



Mos përdorni silikon që në përbërje ka acid acetik.



Justimi (shih faqen 42)

Rregullimi i kufizimit me ujë të nxehtë. Nje kombinim me një bojler ujit nuk është i rekomanduar.



Mirëmbajtja (shih faqen 54)

Penguesit e rrjedhjes në drejtim të kundërt duhen kontrolluar rregullisht në bazë të normave EN 806-5 konform normave nacionale dhe regionale (së paku një herë në vit).



Përmasat (shih faqen 43)



Diagrami i qarkullimit (shih faqen 43)



Pjesët e servisit (shih faqen 51)

XXX = Kodimi me anë të ngjyrave
 000 = Krom
 340 = Brushed Black Chrome
 670 = Matt Black
 800 = Optikë Çeliku

Pajisje të posaçme

(nuk përfshihet në vëllimin e furnizimit)



F12 Zgjatës #43333000 (shih faqen 49)



Pastrimi (shih faqen 47)



Përdorimi (shih faqen 50)

Hansgrohe rekomandon që në mëngjes ose pas periudhave të gjata që gjysmë litri i parë mos të pihet



Shenja e kontrollit (shih faqen 56)

Dëmtim

Shkaku

Ndihme

Armatura punon rende	- Kartusha me defekt, me kalk	- Kembeni kartushen
Armatura pikon	- Kartusha me defekt	- Kembeni kartushen
Dalje e ujit ne cilindrin fiksues	- Tubat e lidhjes jo komplet te vidhosur ne karkasen baze	- Shtrengojini manualisht tubat e lidhur
	- Unaza ○ tek tubi lidhes me defekt	- Kembeni unazen ○
Temperaturë e ulët e ujit të ngrohtë	- Kufiri i ujit te ngrohte eshte regjistruar gabim	- Regjistroni kufirin e ujit te ngrohte



الصيانة (راجع صفحة 54)

تنبيهات الأمان

يجب فحص صمام عدم الرجوع بصفة منتظمة حسب المواصفة 5-EN 806 وذلك طبقاً للوائح الوطنية أو الإقليمية (مرة واحد سنوياً على الأقل).

⚠ يجب ارتداء قفازات لليد أثناء التركيب لتجنب حدوث أخطار الإنحشار أو الجروح.
⚠ يجب أن يكون تيار الماء الساخن والماء البارد متعادلين في الضغط.

أبعاد (راجع صفحة 43)

رسم للصرف (راجع صفحة 43)

قطع الغيار (راجع صفحة 51)

XXX = الألوان
000 = كروم
Brushed Black Chrome = 340
Matt Black = 670
800 = مظهر الإستنليس ستيل

ملحقات خاصة

(غير مدرج مع المحتويات المسلمة)

F12 وصلة إطالة #43333000
(راجع صفحة 49)

التنظيف (راجع صفحة 47)

التشغيل (راجع صفحة 50)

تنصح شركة هانزجرهوي Hansgrohe بعدم استخدام أول نصف لتر من الماء لغرض الشرب وذلك في الصباح أو بعد توقف استخدام الماء لفترات طويلة نسبياً.

شهادة اختبار (راجع صفحة 56)

تعليمات التركيب

- قبل القيام بعملية التركيب، يجب فحص المنتج للتأكد من خلوه من أية تلفيات ناتجة عن النقل. بعد القيام بعملية التركيب، لن يتم الاعتراف بوجود أية تلفيات سطحية أو تلفيات ناتجة عن عملية النقل.
- يجب تركيب وغسيل واختبار التوصيلات وخلطات المياه طبقاً للمعايير السارية.
- يجب مراعاة القواعد الخاصة بالتركيب وأعمال السباكة وفقاً للوائح الخاصة بكل بلد.

المواصفات الفنية

ضغط التشغيل: الحد الأقصى 1 ميجاباسكال
ضغط التشغيل الموصى به: 0,1 - 0,5 ميجاباسكال
ضغط الاختبار: 1,6 ميجاباسكال
(1 ميجاباسكال = 10 بار = 147 PSI)
درجة حرارة الماء الساخن: الحد الأقصى 60°C
تغيم حراري: 4 / 70°C الدقيقة
المنتج مخصص فقط لماء الشرب!

وصف الرمز

هام! لا تستخدم السليكون الذي يحتوي على أمحاض!

الضبط (راجع صفحة 42)

ضبط تحديد المياه الدافئة لا ينصح باستخدام محدد المياه الدافئة مع سخان المياه الوقتي.

العطل	السبب	العلاج والإصلاح
الخلاط ثقيل الحركة	- الخرطوشة تالفة، تراكم عليها الجير	- قم بتغيير الخرطوشة
تساقط قطرات مياه من الخلاط	- الخرطوشة تالفة	- قم بتغيير الخرطوشة
خروج الماء من جزء التثبيت	- خراطيم التوصيل ليست مربوطة في الجزء الرئيسي بشكل كامل	- اربط خراطيم التوصيل بيدك
	- الحلقة الدائرية الخاصة بخراطيم التوصيل تالفة	- قم بتغيير الحلقة الدائرية
درجة حرارة الماء الساخن منخفضة للغاية	- محدد الماء الساخن مضبوط بشكل خاطيء	- قم بضبط محدد الماء الساخن



Biztonsági utasítások

- △ A szerelésnél a zúzódasok és vágási sérülések elkerülése érdekében kesztyűt kell viselni.
- △ A hidegvíz- és a melegvíz-csatlakozások közötti nagy nyomáskülönbséget kikell egyenlíteni!

Szerelési utasítások

- A szerelés előtt ellenőrizni kell, hogy a terméknek nincs-e szállítási sérülése. Beépítés után a szállítási- vagy felületi sérüléseket nem ismerik el.
- A vezetékeket és a csaptelepet az érvényes szabványoknak megfelelően kell felszerelni, öblíteni és ellenőrizni
- Az egyes országokban érvényes installációs irányelveket be kell tartani.

Műszaki adatok

Üzemi nyomás:	max. 1 MPa
Ajánlott üzemi nyomás:	0,1 - 0,5 MPa
Nyomáspróba:	1,6 MPa
	(1 MPa = 10 bar = 147 PSI)
Forróvíz hőmérséklet:	max. 60 °C
Termikus fertőtlenítés:	70 °C / 4 perc

A terméket kizárólag ivóvízhez tervezték!

Szimbólumok leírása



Ne használjon ecetsavtartalmú szilikont!



Beállítás (lásd a oldalon 42)

A meleg víz korlátozás beállítása. Átfolyós vízmelegítőknél meleg víz korlátozó használata nem ajánlott.



Karbantartás (lásd a oldalon 54)

A visszafolyásgátlók működése a EN 806-5 szabványnak megfelelően, a nemzeti vagy területi rendelkezésekkel összhangban, évente egyszer ellenőrizendő!



Méretet (lásd a oldalon 43)



Átfolyási diagramm

(lásd a oldalon 43)



Tartozékok (lásd a oldalon 51)

- XXX = Színkódolás
- 000 = Króm
- 340 = Brushed Black Chrome
- 670 = Matt Black
- 800 = Acéloptika

Egyéb tartozék

(a szállítási egység nem tartalmazza)



F12 Hosszabbítás #43333000
(lásd a oldalon 49)



Tisztítás (lásd a oldalon 47)



Használat (lásd a oldalon 50)

- A csaptelepeken átfolyt víz hőmérséklete fogyasztásra szánt víz esetében a 65 °C-ot nem haladhatja meg. A csaptelep nem eredményezheti az emberi fogyasztásra (pl. ivás és főzés céljából) szánt víz minőségromlását.
- Beüzemelés és üzemszünetek után szigorúan be kell tartani a használati útmutatóban leírtakat. Beüzemeléskor a csaptelepet át kell öblíteni, legalább 2 percig történő hideg- és melegvízes folyatást javasolunk. Minimum 1 napos üzemszünet után fogyasztás előtt a csaptelepben stagnáló hideg- illetve melegvíz fogyasztása nem javasolt, a csaptelepben stagnáló vizet ki kell engedni, legalább 2 perces folyatás javasolt. A kifolyatás során nyert vizet ivóvízként, illetve ételkészítési céllal felhasználni nem szabad.
- Tekintettel arra, hogy a forró víz fémoldó képessége a hideg víznél nagyobb, emiatt főzés ivás céljából az OKI a hideg víz használatát javasolja.
- A csaptelepek perlátorát javasolt havonta vízkőteleníteni, illetve fertőtleníteni. A csaptelepek tisztítása, fertőtlenítése során kizárólag olyan vegyszer alkalmazható, amely megfelel a 201/2001. (X.25) Kormányrendelet, illetve a 38/2003. (VII.7) ÉSzCsM-FVM-KvVM együttes rendeletben leírtaknak.
- A perlátor működési elvéből adódóan jelentős aeroszolt képez, így Legionella expozíció szempontjából fokozott kockázatot jelent. Ezért alkalmazása nem javasolt az egészségügyi intézmények fekvőbeteg ellátó szobáiban, illetve minden olyan helyen, ahol a hideg és / vagy használati melegvíz Legionella csíraszám eléri a 49/2015 (XI.6.) EMMI rendelet alapján meghatározott beavatkozási szintet.



Vizsgajel (lásd a oldalon 56)



Hiba	Ok	Megoldás
Nehezen nyitható a csap.	- A kerámiabetét meghibásodott, elvízkövesedett.	- A kerámiabetétet ki kell cserélni.
Csöpög a csap.	- A kerámiabetét meghibásodott.	- A kerámiabetétet ki kell cserélni.
Vízkilépés a rögzítőrúdon	- A csatlakozótömlők nincsenek teljesen becsavarozva az akaptestbe	- A csatlakozótömlőket kézzel meghúzni
	- Csatlakozótömlő tömítőgyűrűje meghibásodott	- Tömítőgyűrű kicserélése
túl alacsony melegvíz hőmérséklet	- A melegvíz szabályozó rosszul van beállítva.	- A melegvíz szabályozót újra be kell állítani.

**安全上の注意**

- △ 施工の際は手を挟んだり怪我をしないように、手袋をはめてください。
- △ 給水・湯の圧力差は0.1(MPa)以内としてください。

施工上の注意

- ・製品の施工前に輸送でのダメージがないか確認してください。施工後のキズ等のお申し出はお断りさせて頂いています。
- ・配管と水栓は、関連法規に従って施工、洗浄、および試験を行ってください。
- ・施工行う地域に適用される関連法規をお守りください。

技術資料

使用圧力: 最大 1 MPa
 推奨使用水圧: 0,1 - 0,5 MPa
 耐圧試験圧力: 1,6 MPa
 (1 MPa = 10 bar = 147 PSI)

給湯温度: 最大 60°C
 お湯による高温消毒: 70°C / 4分
 この製品は飲料水での使用が前提となっています
 (日本においては水道法に適合する飲料水)!

アイコンの説明

酢酸系シリコンをご使用にならないでください!



調整 (次のページを参照 42)

お湯の流量制限の設定方法。瞬間湯沸かし器をご利用の際はお湯の流量制限はしないでください。



メンテナンス (次のページを参照 54)

逆止弁は、EN 806-5に従って定期的(少なくとも年に1回)に確認をしてください(日本においては関連法規に従ってください)。



寸法 (次のページを参照 43)



流量曲線図 (次のページを参照 43)



スペアパーツ (次のページを参照 51)

XXX = 仕上げ色
 000 = Chrome
 340 = Brushed Black Chrome
 670 = Matt Black
 800 = Stainless Steel Optic

スペシャルパーツ (別手配部品)

F12 延長部材 #43333000
 (次のページを参照 49)



お手入れ方法
 (次のページを参照 47)



使用方法 (次のページを参照 50)

ハンズグローエは、朝または長い間使用されなかった後に吐水する最初の0.5リットルは飲料水として使用しないことをお勧めします。



認証について
 (次のページを参照 56)

症状	原因	対応策
水栓の開閉が重い	- カルキによるカートリッジ不具合	- カートリッジを交換してください
水栓の水漏れ	- カートリッジの不良	- カートリッジを交換してください
固定ネジ部分から水が漏れる	- 接続ホースが本体に完全にねじ込まれていない - 接続ホースのOリングの不具合	- 接続ホースを手で増し締めしてください - Oリングを交換してください
吐水温度が低すぎる	- 温度リミッターの設定が正しくない	- 温度リミッターを設定してください

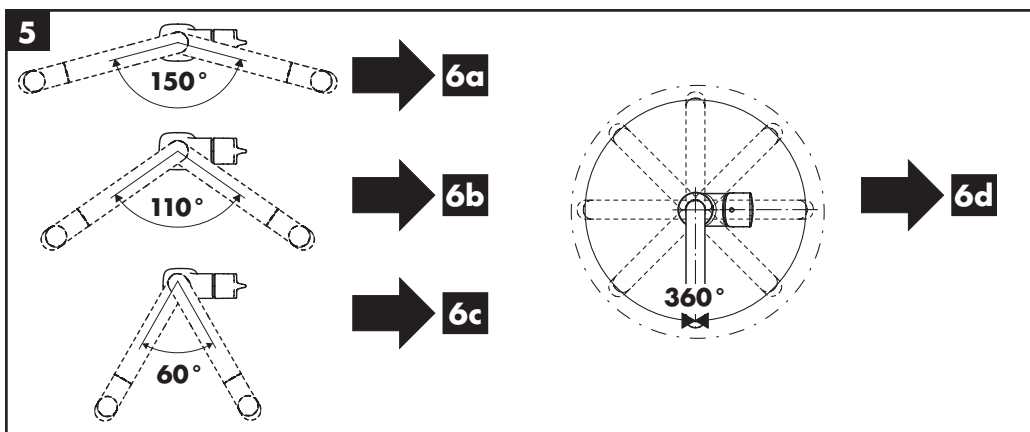
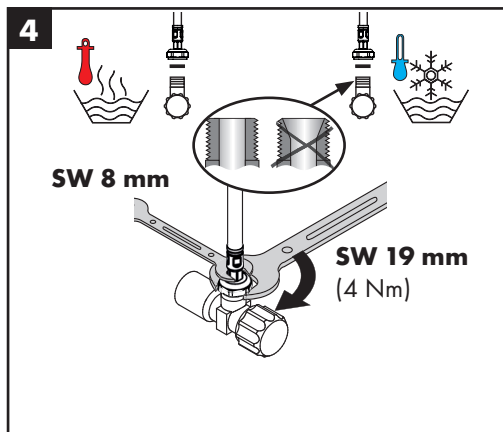
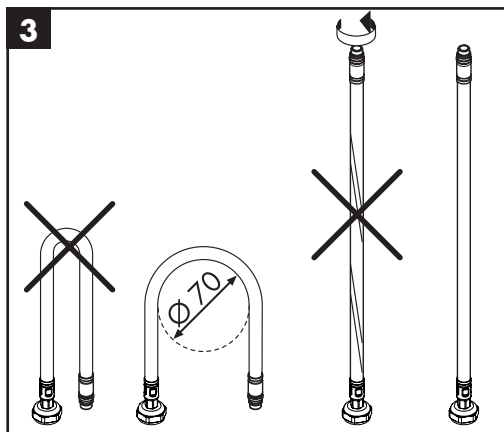
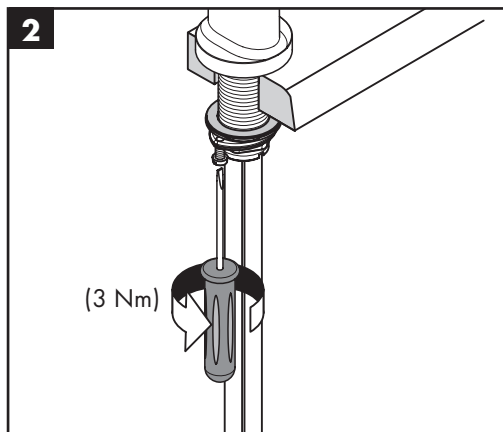
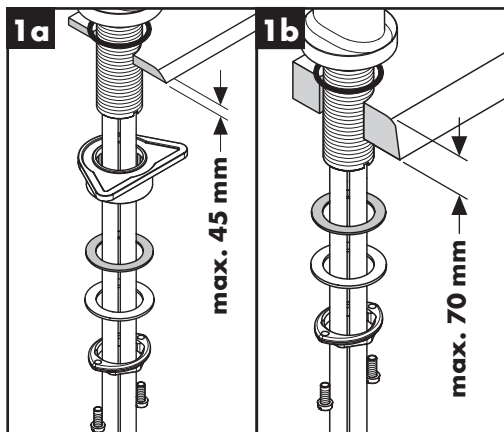



6a

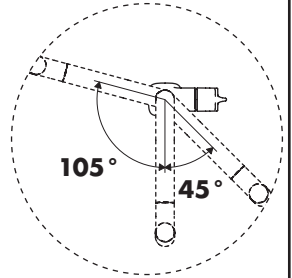
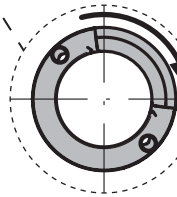
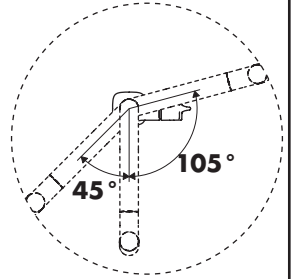
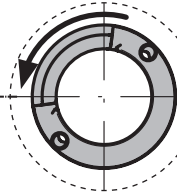
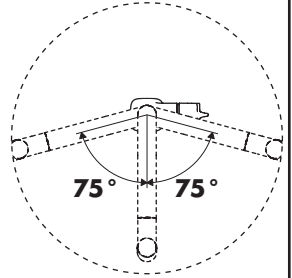
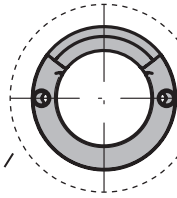
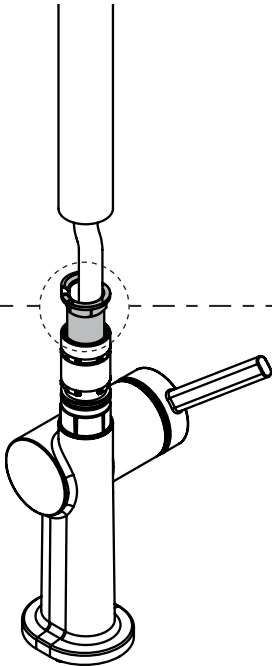
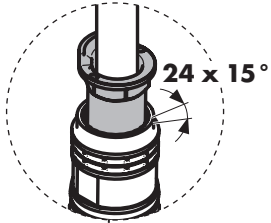
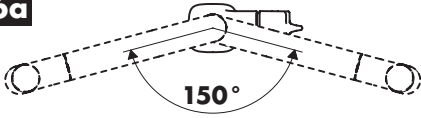



6b

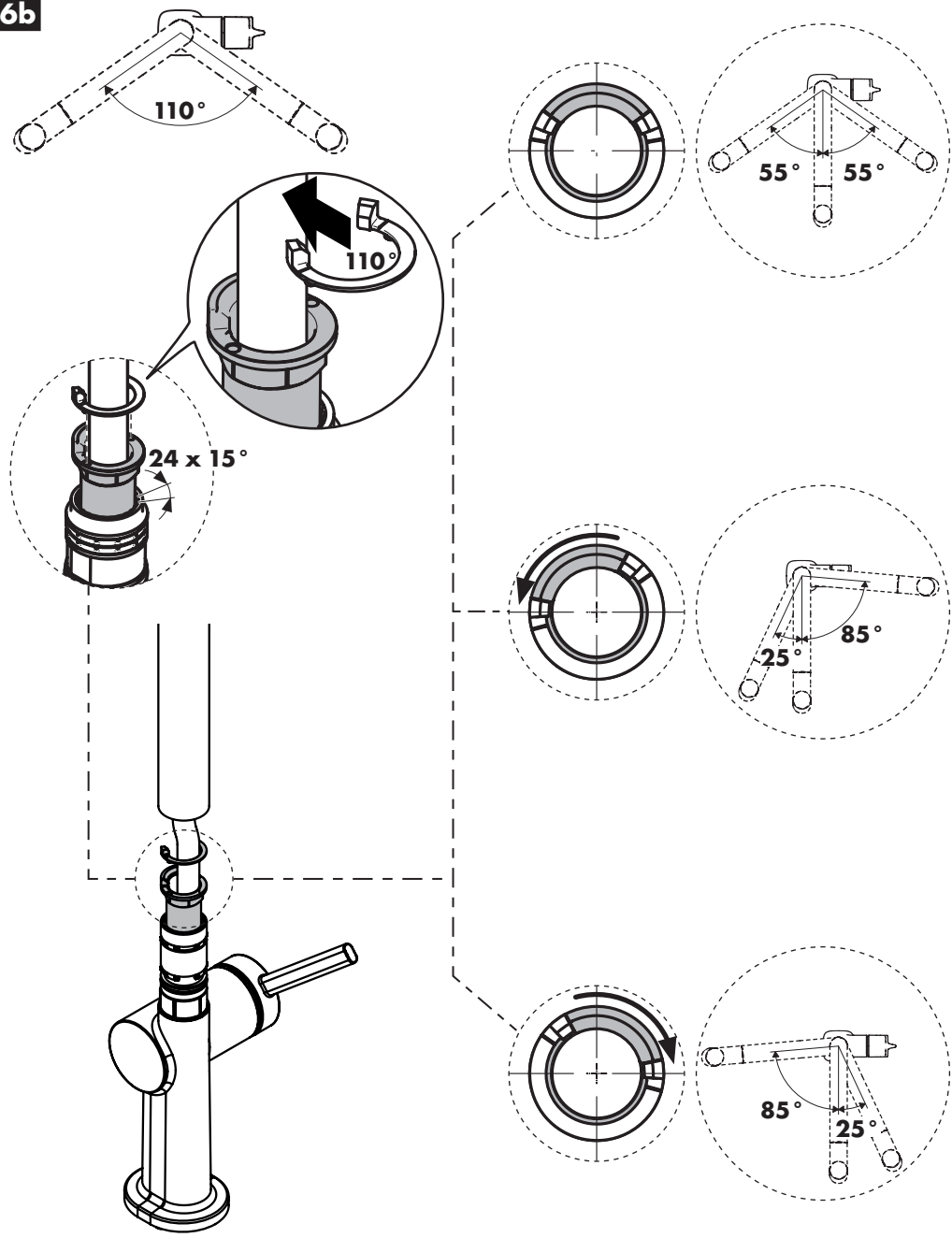



6c

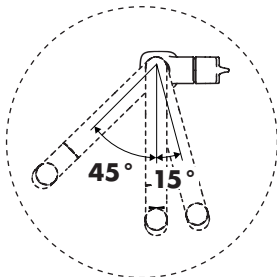
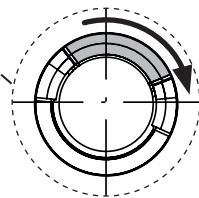
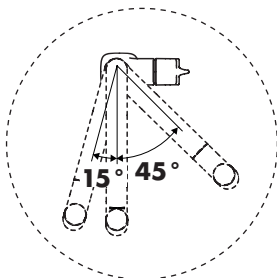
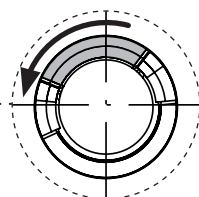
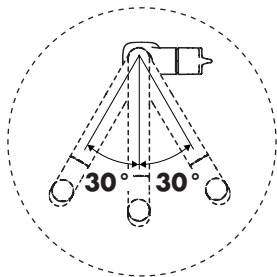
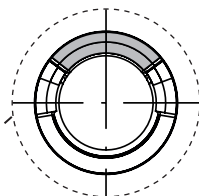
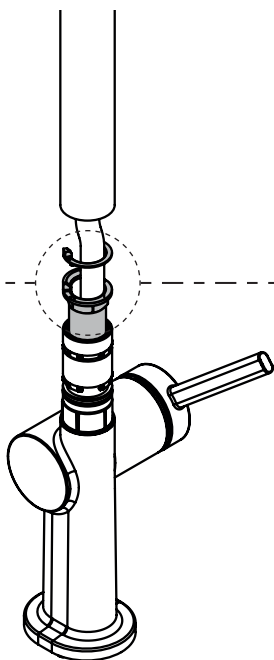
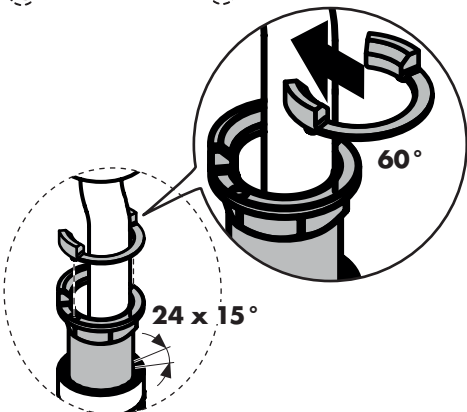
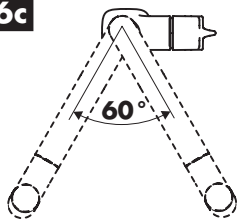



6d

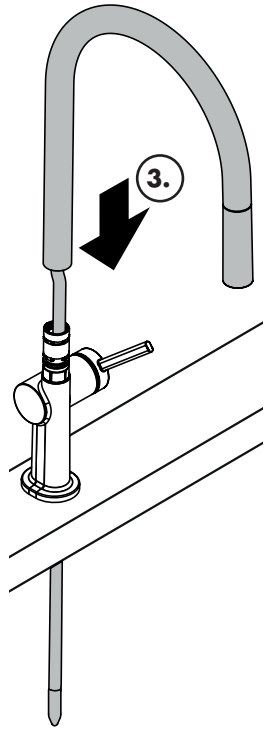
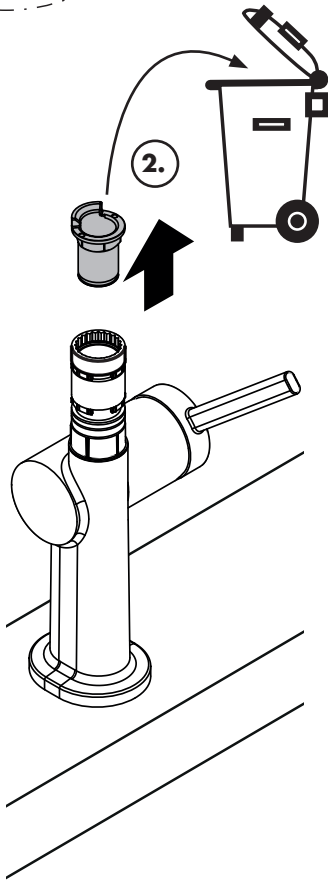
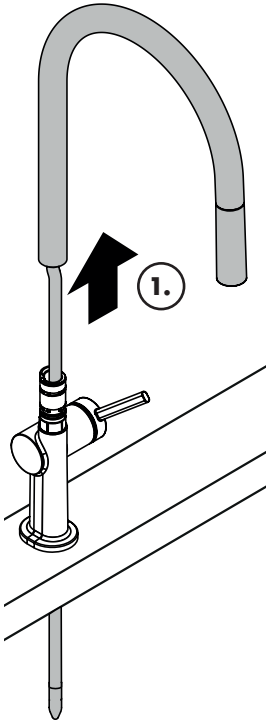
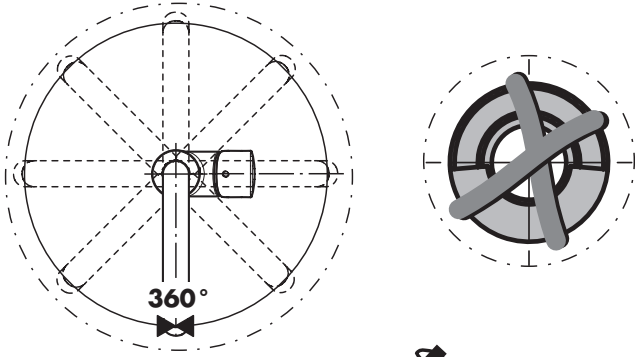

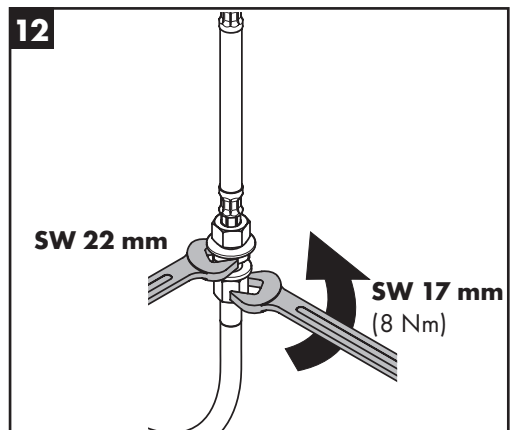
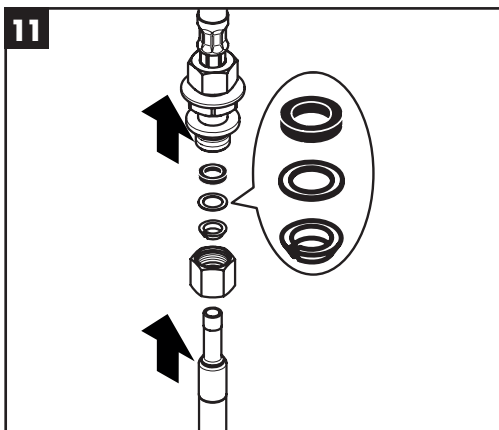
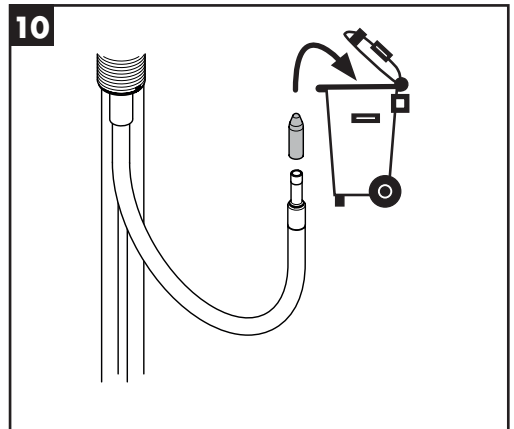
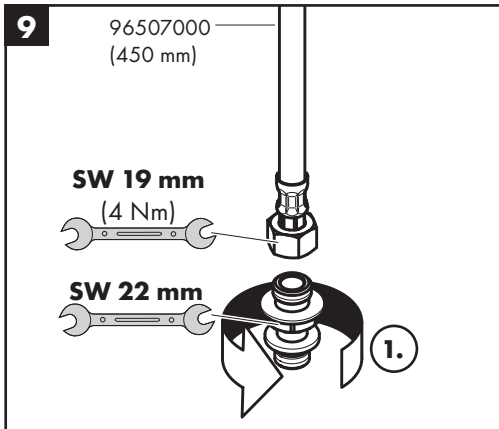
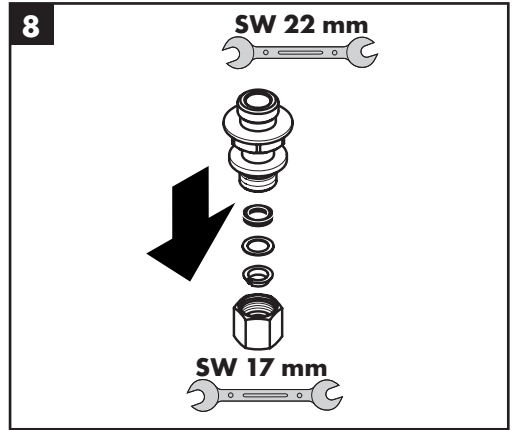
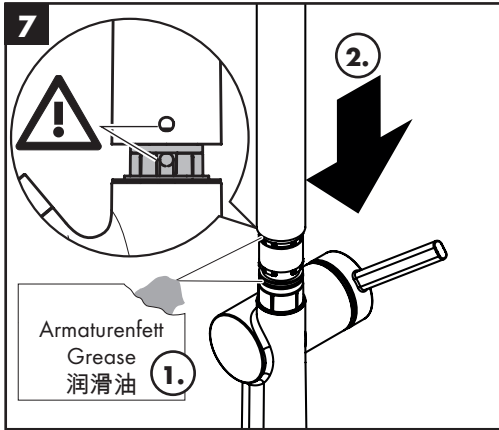

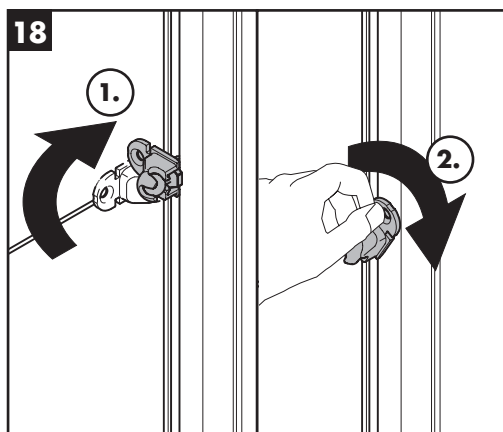
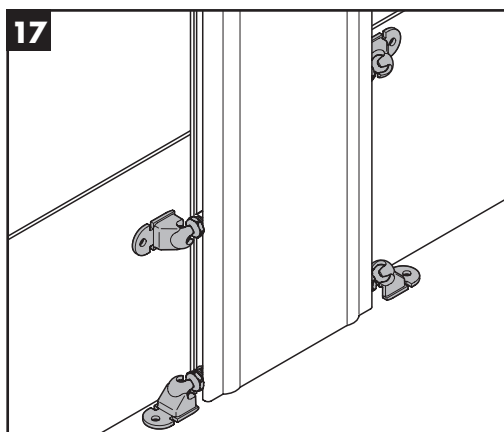
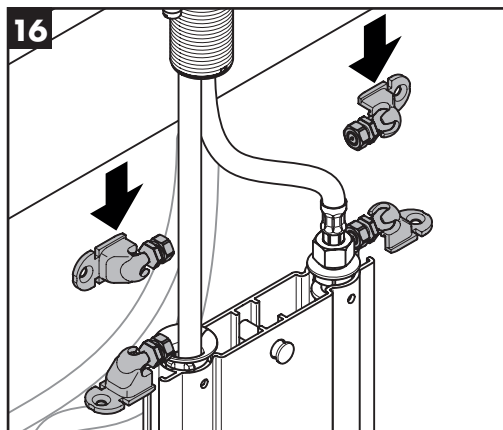
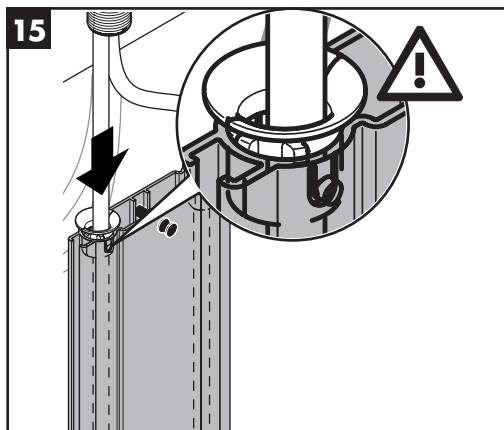
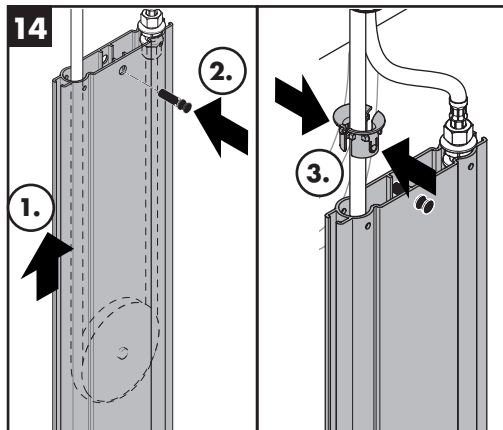
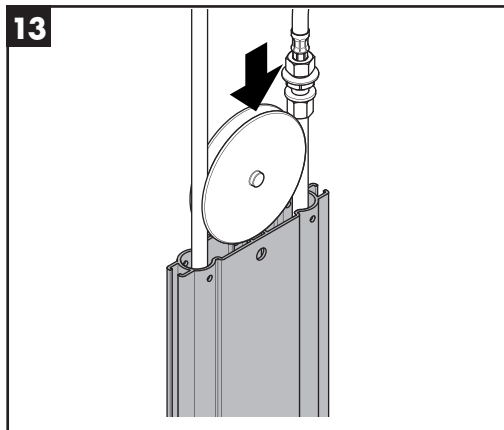

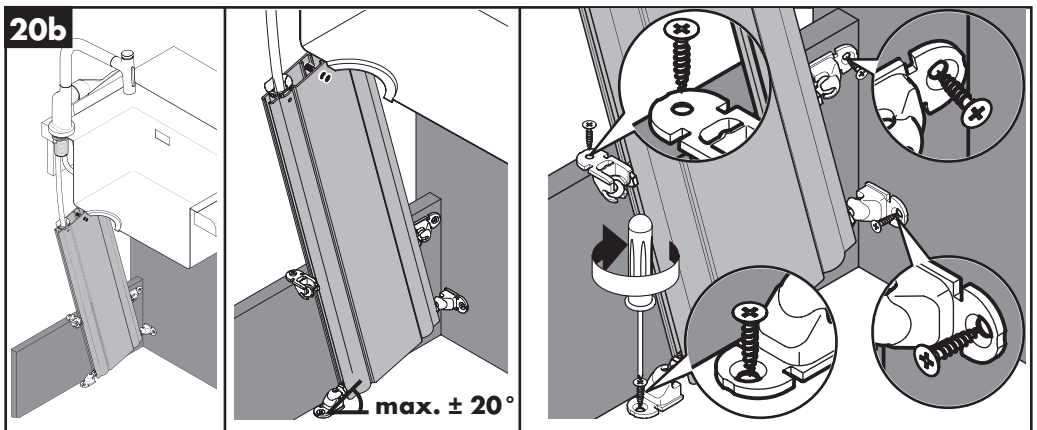
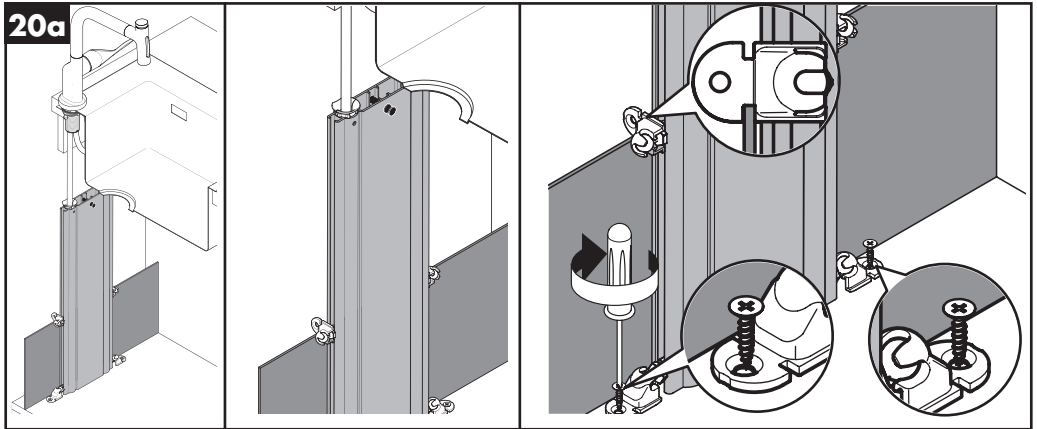
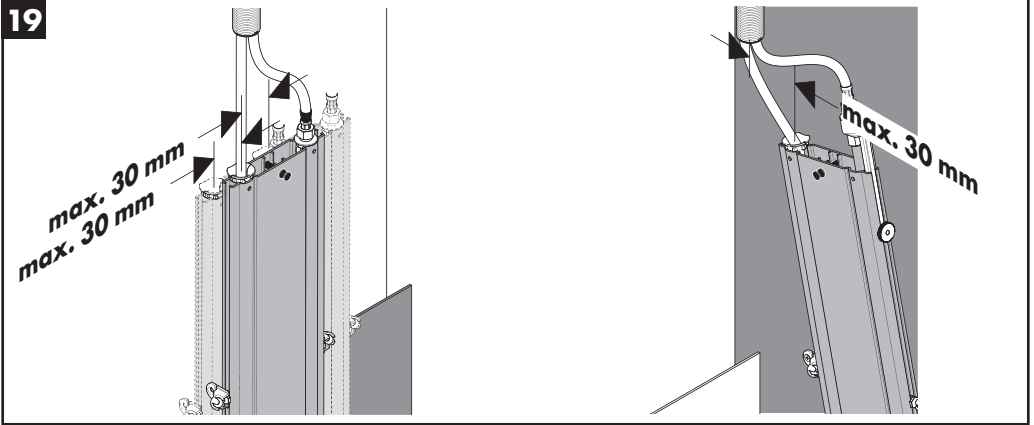

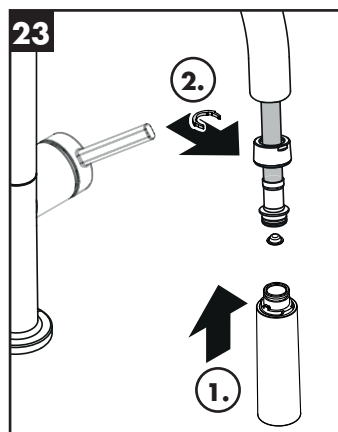
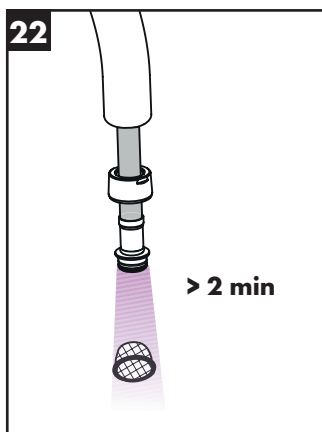
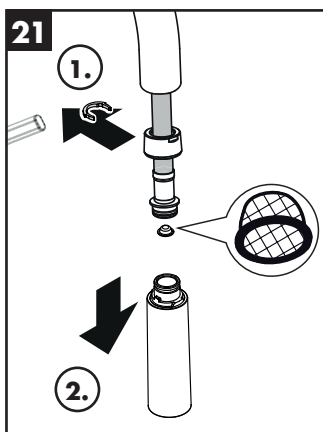
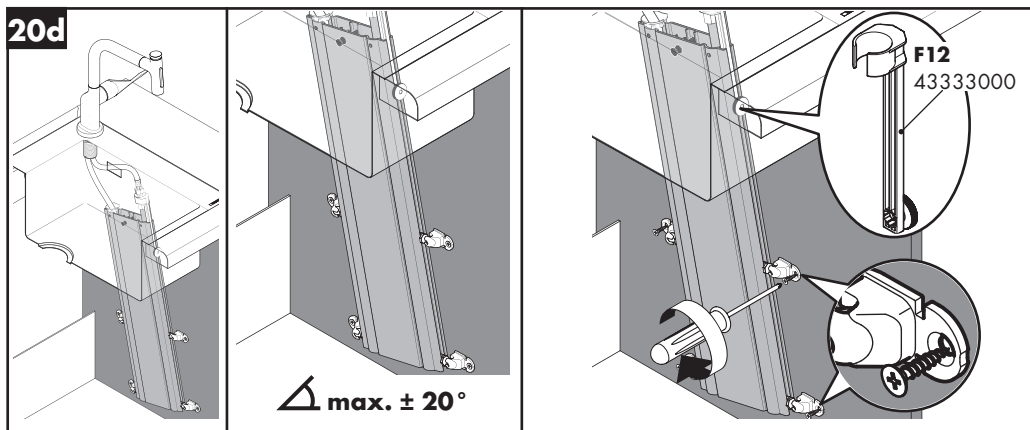
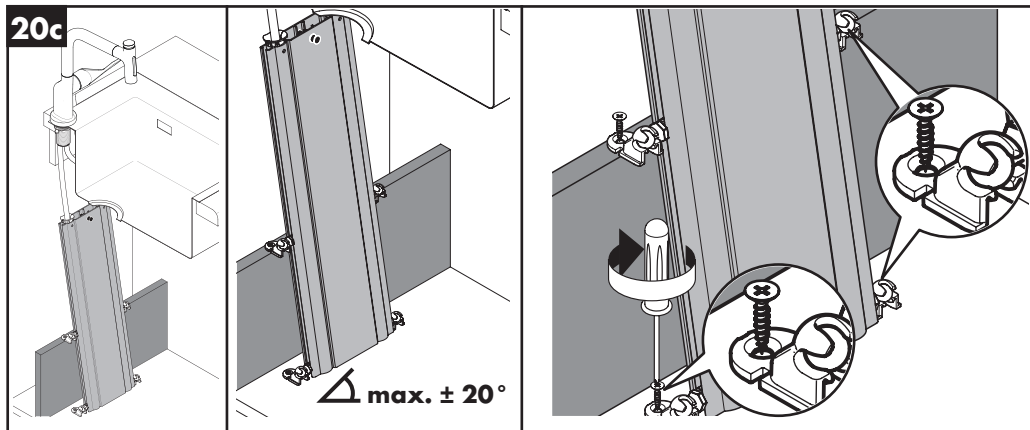

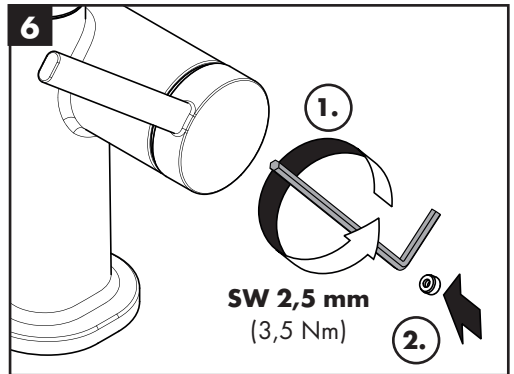
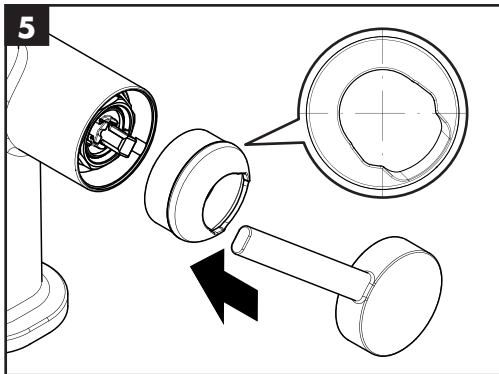
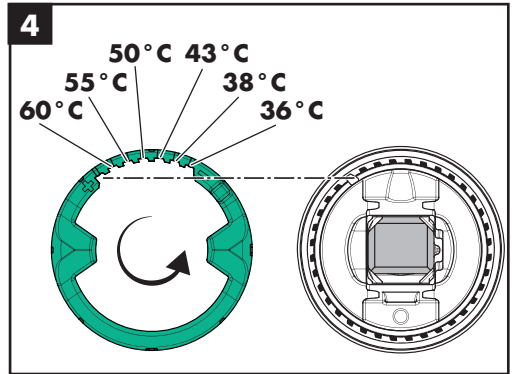
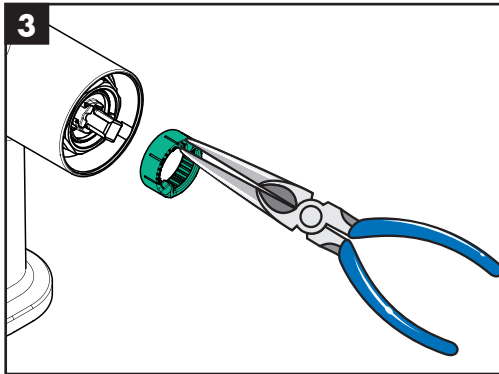
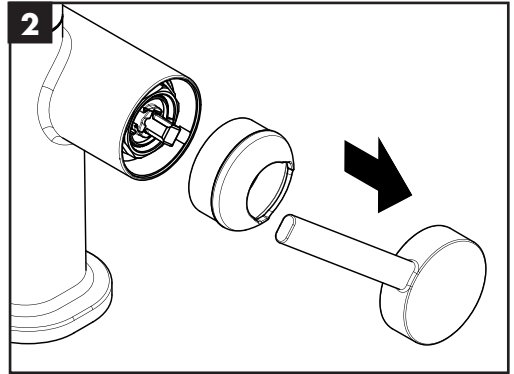
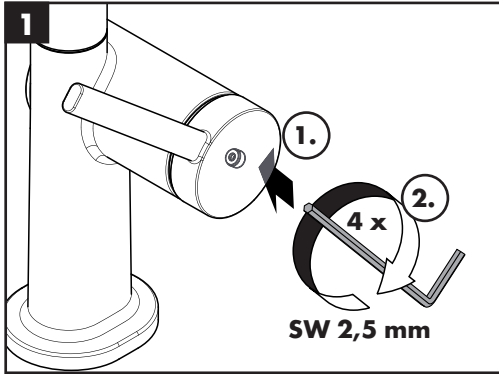



Talis M54 210 1jet sBox

72803XXX

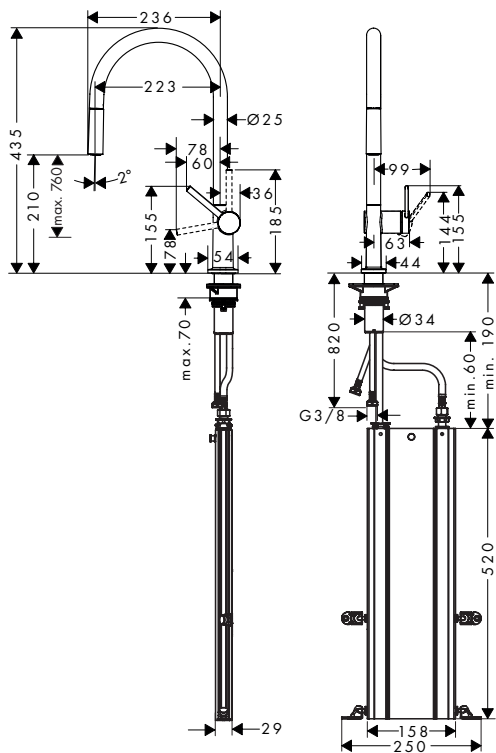

Talis M54 210 1jet sBox

72848000

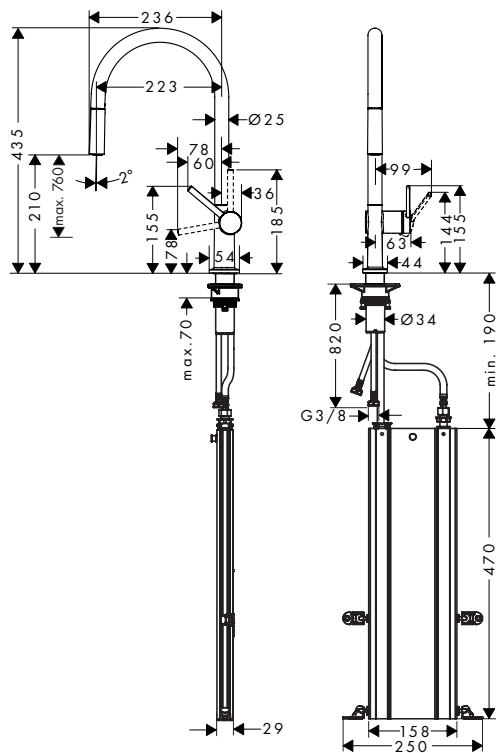

Talis M54 210 1jet sBox

72803XXX / 72848000

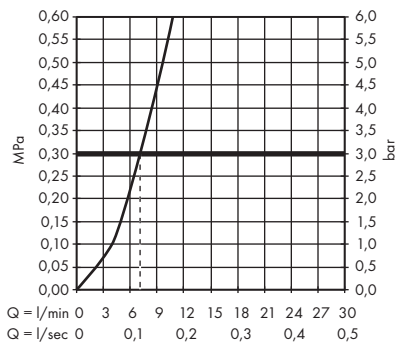



Talis M54 210 2jet sBox
72801XXX

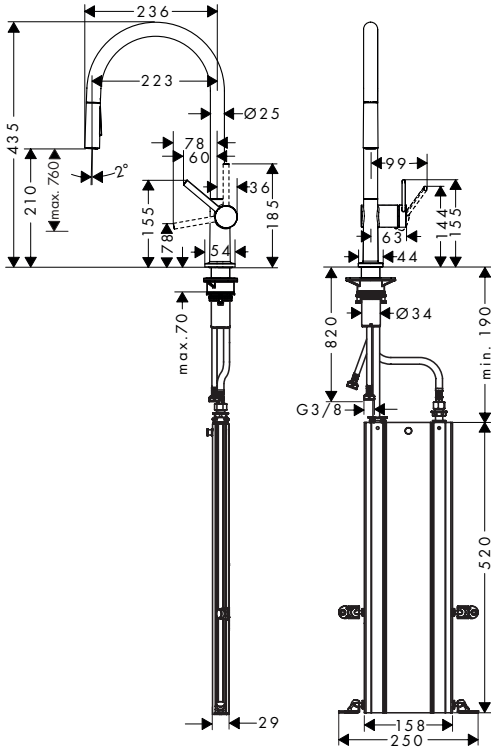

Talis M54 210 2jet sBox
72847000

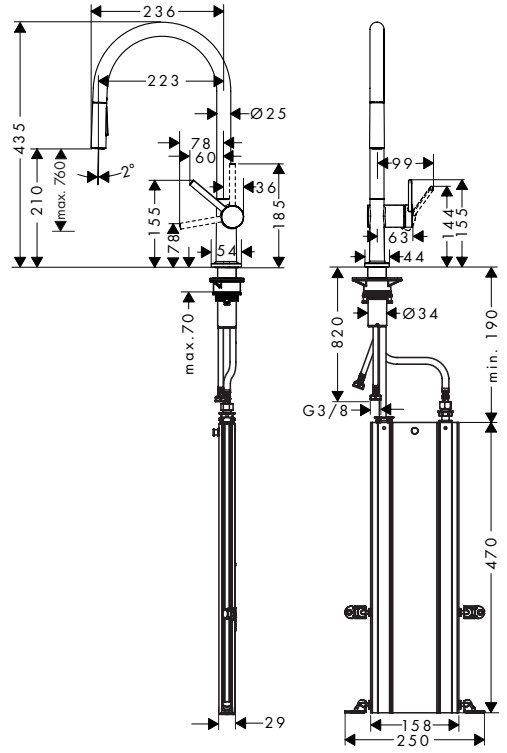

Talis M54 210 2jet sBox
72801XXX / 72847000

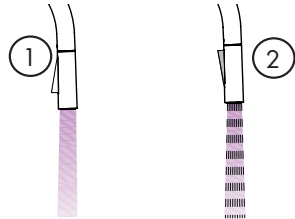
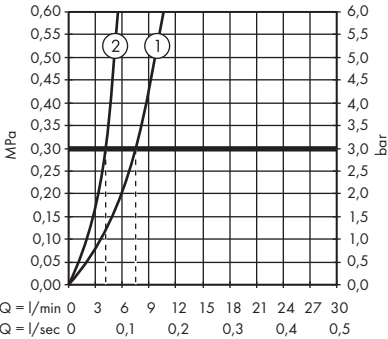

Talis M54 270 1jet sBox
72809XXX

Talis M54 270 1jet sBox
72849000

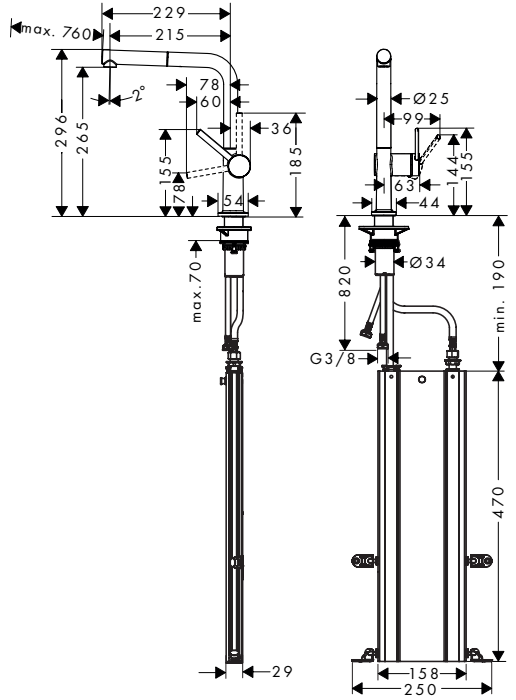
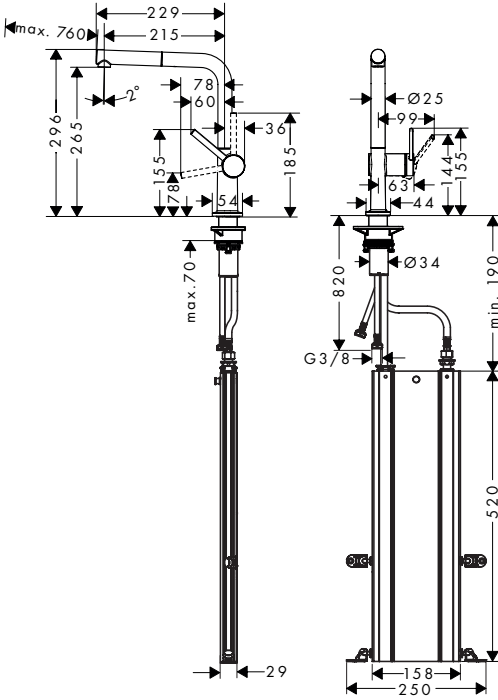

Talis M54 270 1jet sBox
72809XXX / 72849000

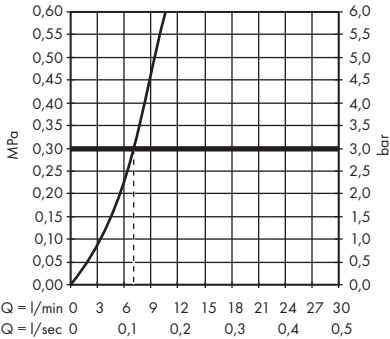



sBox

72803XXX / 72801XXX / 72809XXX

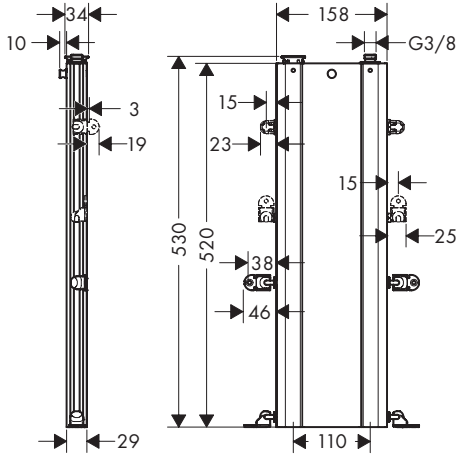

sBox

72847000 / 72848000 / 72849000

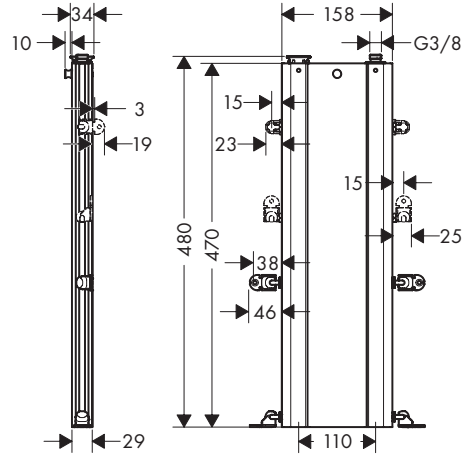



- DE** Reinigungsempfehlung / Garantie / Kontakt
- FR** Recommandation pour le nettoyage / Garanties / Contact
- EN** Cleaning recommendation / Warranty / Contact
- IT** Raccomandazione di pulizia / Garanzia / Contatto
- ES** Recomendaciones para la limpieza / Garantía / Contacto
- NL** Aanbevelingen inzake reiniging / Garantie / Contact
- DK** Rengøringsvejledning / Garanti / Kontakt
- PT** Recomendações de limpeza / Garantia / Contacto
- PL** Zalecenie dotyczące pielęgnacji / Gwarancja / Kontakt
- CS** Doporučení k čištění / Záruka / Kontakt
- SK** Odporúčania pre čistenie / Záruka / Kontakt
- ZH** 清洁指南 / 担保 / 接触
- RU** Рекомендации по очистке / Гарантия / Контакты
- FI** Puhdistussuositus / Takuu / Kosketus
- SV** Rengöringsrekommendationer / Garanti / Contacto
- LT** Valymo rekomendacijos / Garantija / Kontaktai
- HR** Preporuke za čišćenje / Garancija / Kontakt
- TR** Temizleme önerisi / Garanti / Temas
Garanti belgesi ve koşulları için www.hansgrohe.com.tr web sitesini ziyaret ederek; dijital garanti belgenize ulaşabilirsiniz.
- RO** Recomandări pentru curățare / Garanție / Contact
- EL** Σύσταση καθαρισμού / Εγγύηση / επαφή
- SL** Priporočilo za čiščenje / Garancija / Kontakt
- ET** Puhastussooitused / Garantii / Kontakt
- LV** Tīrīšanas ieteikumi / Garantija / Kontakti
- SR** Preporuke za čišćenje / Garancija / Kontakt
- NO** Anbefaling for rengjøring / Garanti / Kontakt
- BG** Препоръка за почистване / Гаранция / Контакт
- SQ** Këshilla rreth pastrimit / Garancia / Kontakt
- KO** 세정시 권장사항 / 품질보증 / 접촉
- AR** توصيات التنظيف / الضمان / اتصال
- HU** Tisztítási tanácsok / Garancia / érintkezés
- JP** お手入れの方法 / 保証について / ご連絡先



[www.hansgrohe.com/
cleaning-recommendation](http://www.hansgrohe.com/cleaning-recommendation)

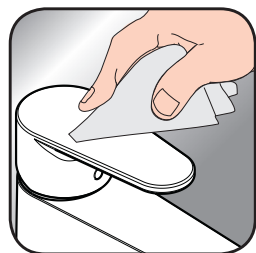

[www.hansgrohe.com/
cleaning-recommendation](http://www.hansgrohe.com/cleaning-recommendation)



[www.hansgrohe.com/
cleaning-recommendation](http://www.hansgrohe.com/cleaning-recommendation)



[www.hansgrohe.com/
cleaning-recommendation](http://www.hansgrohe.com/cleaning-recommendation)

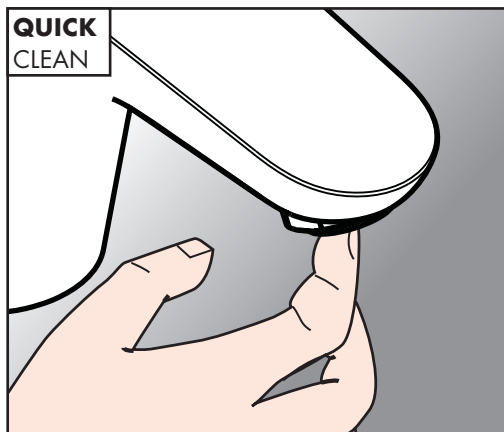

- DE** Einfach sauber: Kalk lässt sich von den Noppen ganz leicht abrubbeln.
- FR** La propreté en toute simplicité: les dépôts formés sur les buses élastiques en silicone s'éliminent par un simple passage de la main.
- EN** Just clean: simply rub over the spray nozzles to remove lime scale.
- IT** Facile da pulire: Il calcare viene eliminato semplicemente dagli ugelli elastici in silicone.
- ES** Fácil asear: La cal se puede retirar sencillamente frotando con los dedos de las toberas elásticas de silicona.
- NL** Eenvoudig schoon: Kalk kan eenvoudig van de noppen worden gewreven.
- DK** Enkel rengøring: Det er let at fjerne kalkaflejringer fra stråledyserne.
- PT** Simplesmente limpo: o calcário pode ser simplesmente retirado das saliências através de fricção.
- PL** Po prostu czysto: Pęczki można całkiem łatwo oczyścić z kamienia.
- CS** Jednoduše čistě: Vapenné usazeniny můžete z popků snadno odstranit oříením.
- SK** Jednoducho čistý: Vodný kameň sa dá zo štetín celkom ľahko odstrániť.
- ZH** 清洁: 只需要揉搓花洒表面的出水孔即可去除水垢。
- RU** Простота чистки: известь очень легко стирается с утолщений.
- FI** Yksinkertaisesti puhdas: kalkin voi helposti hieroa irti nypystä.
- SV** Enkelt att göra rent: det är lätt att ta bort kalk från pöpporna.
- LT** Paprasta švara: kalkės lengvai nugrandomos nuo kilpos.
- HR** Jednostavno čisto: Kamenac se sasvim lako uklanja s izbočina.
- TR** Sadece temiz: Kireç, düğümlerle kolayca ovalanabilir.
- RO** Pur și simplu curat: Calcarul se îndepărtează ușor de pe noduri prin frecare.
- EL** Απλά τέλεια καθαριότητα: Τα άλατα μπορούν να αφαιρεθούν με μεγάλη ευκολία από τα στόμια.
- SL** Preprosto čisto: arpenec se z lahkoto podrgne z vozličkov.
- ET** Lihtsalt puhas: lupja saab nappudelt lihtsalt maha hõõruda.
- LV** Vienkārša tīrīšana: kaļķis no izvirzījumiem ir viegli norubināms.
- SR** Jednostavno čisto: Kamenac se sasvim lako skida sa izbočina.
- NO** Simpelten ren: Ved å gnikke er det lett å fjerne kalk fra nuppene.
- BG** Просто чисто: Варовикът лесно може да се изтърси от удебеленията.
- SQ** Thjesht dhe pastër. Mbetjet gëlqerore mund të hiqen me fërkim të lehtë.
- AR** إنه سهل التنظيف، حيث يسقط الجير بسهولة شديدة من الأجزاء الناتئة
- HU** Egyszerűen tisztá: a vízkő egészen könnyen ledörzsölhető a csomókról.
- JP** 清掃が簡単: カルキは突起部から簡単にこすり落とすことができます。

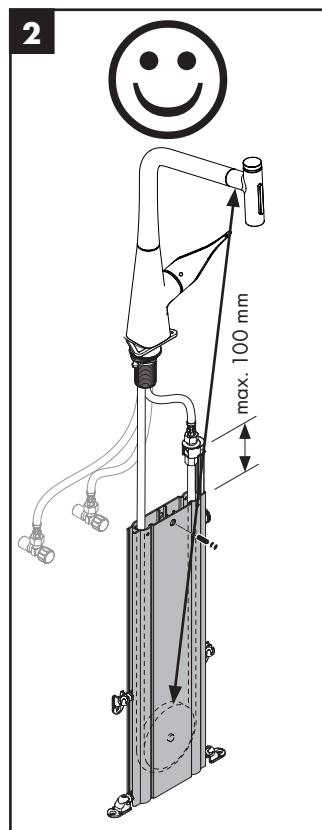
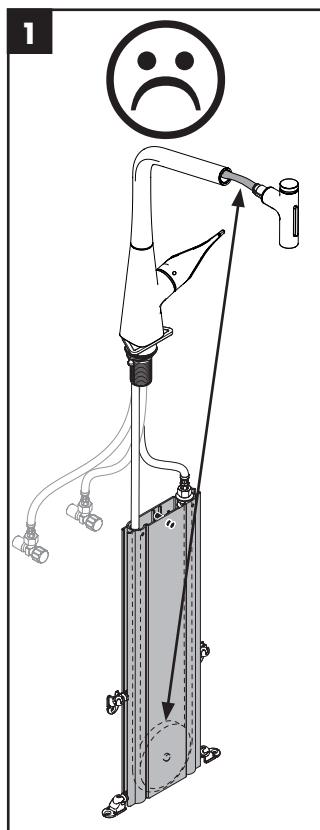
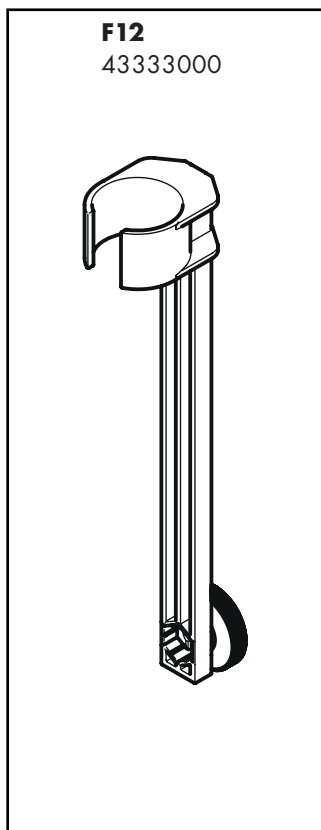
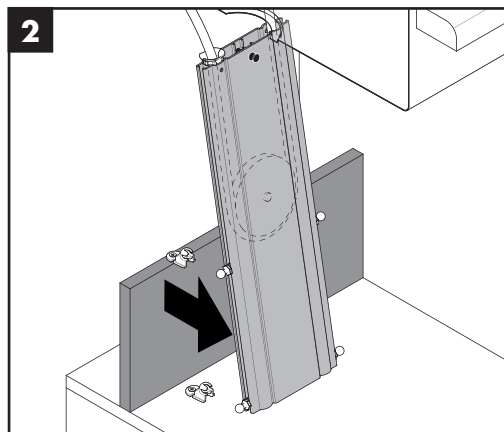
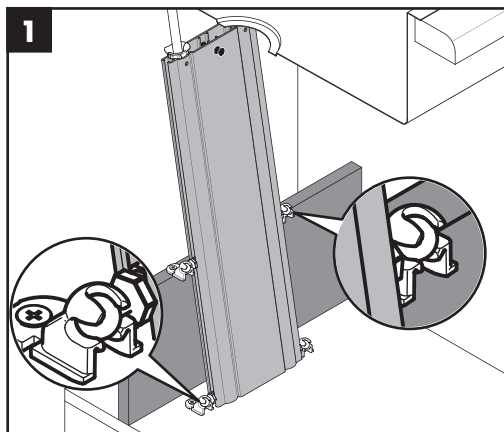

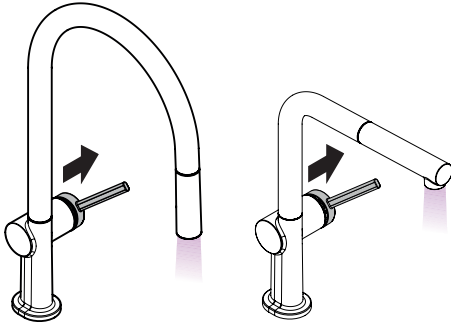

öffnen / ouvert / open / aperto / abierto / open /
 åbne / abrir / otworzyć / otevřít / otvorit' / 开 /
 открыть / nyitás / avaaminen / öppna / atidaryti /
 Otvaranje / açmak / deschide / ανοικτό / odpreti /
 avage / atvērt / otvoriti / åpne / отворяне / hape /
 فتح / 開く

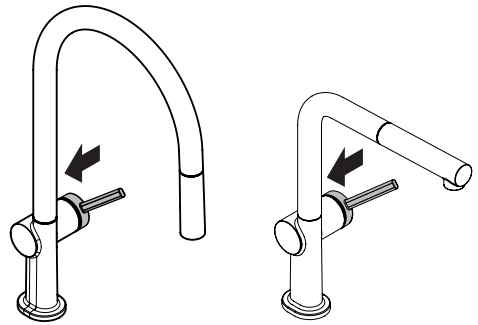

schließen / fermé / close / chiudere / cerrar / sluiten /
 lukke / fechar / zamknąć / zavřít / uzavriev / 关 /
 закрыть / bezárás / sulkeminen / stänga / uždaryti /
 Zatvaranje / kapatmak / închide / κλειστό / zapreti /
 sulgege / aizvērt / zatvori / lukke / затворяне /
 mbylle / إغلاق / 閉じる

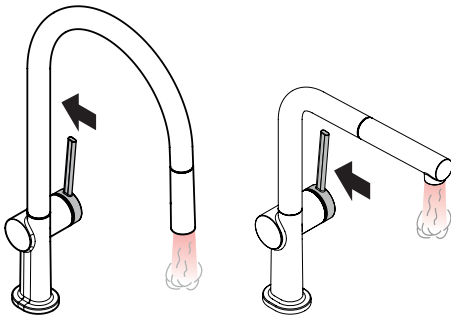

warm / chaud / hot / caldo / caliente / warm / varmt /
 quente / ciepła / teplá / teplá / 热 / горячая / meleg /
 lämmin / varmt / karštas / Vruća voda / sıcak / cald /
 ζεστό / toplo / kuum / karsts / topla / varm / тепло /
 i ngrohtë / ساخن / 温かい

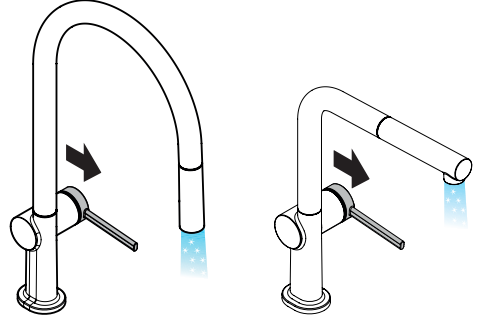

kalt / froid / cold / freddo / frío / koud / koldt / fria /
 zimna / studená / studená / 冷 / холодная / hideg /
 kylmä / kallt / šaltas / Hladno / soğuk / reze / κρύο /
 mrzlo / külm / auksts / hladno / kaldt / студено /
 i frohtë / بارد / 冷たい

Talis M54 210 2jet sBox

72801XXX / 72847000

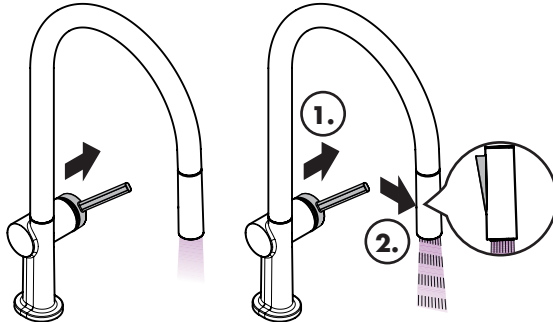



Talis M54 210 2jet sBox

72801XXX / 72847000

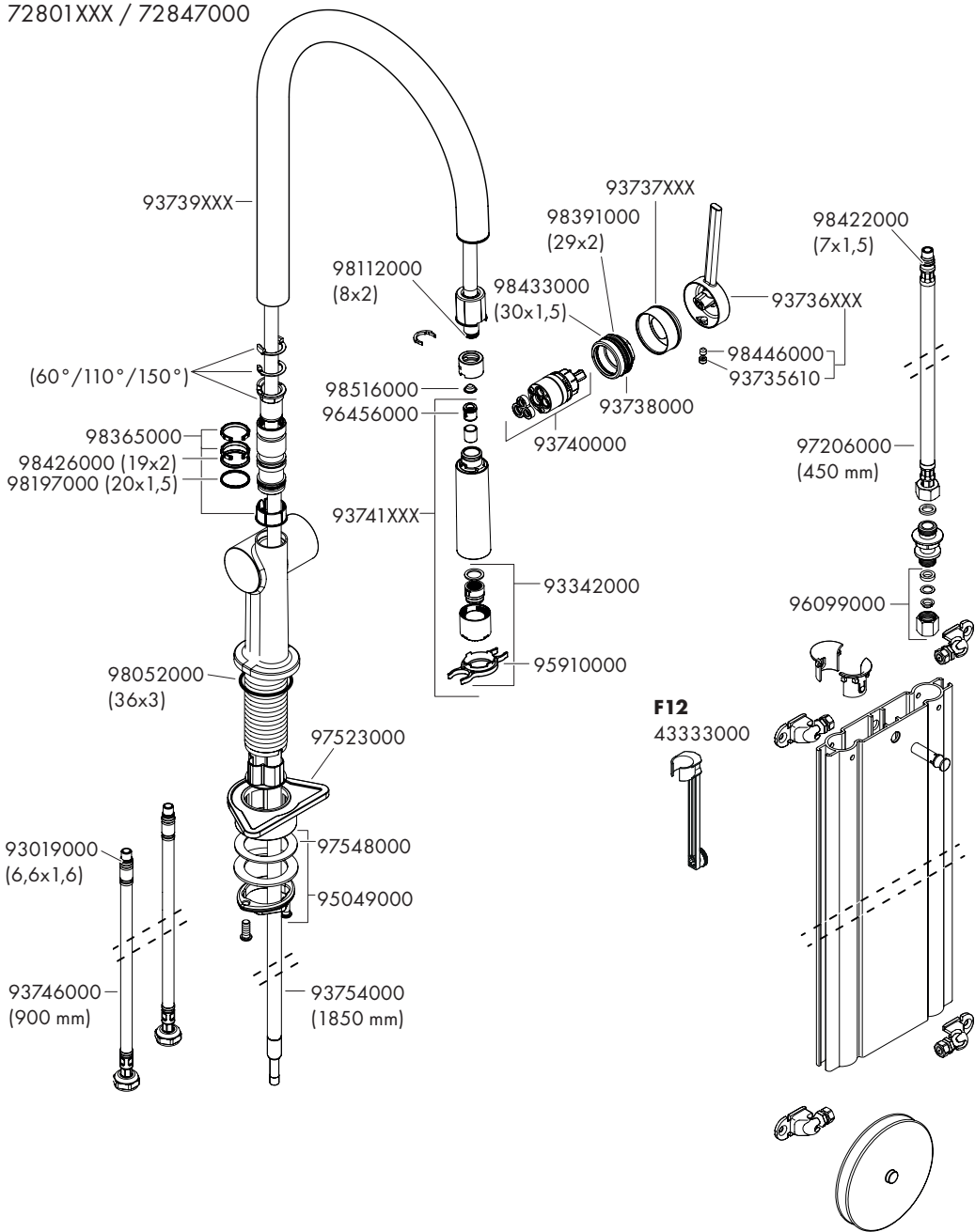



Talis M54 210 Ijet sBox

72803XXX / 72848000

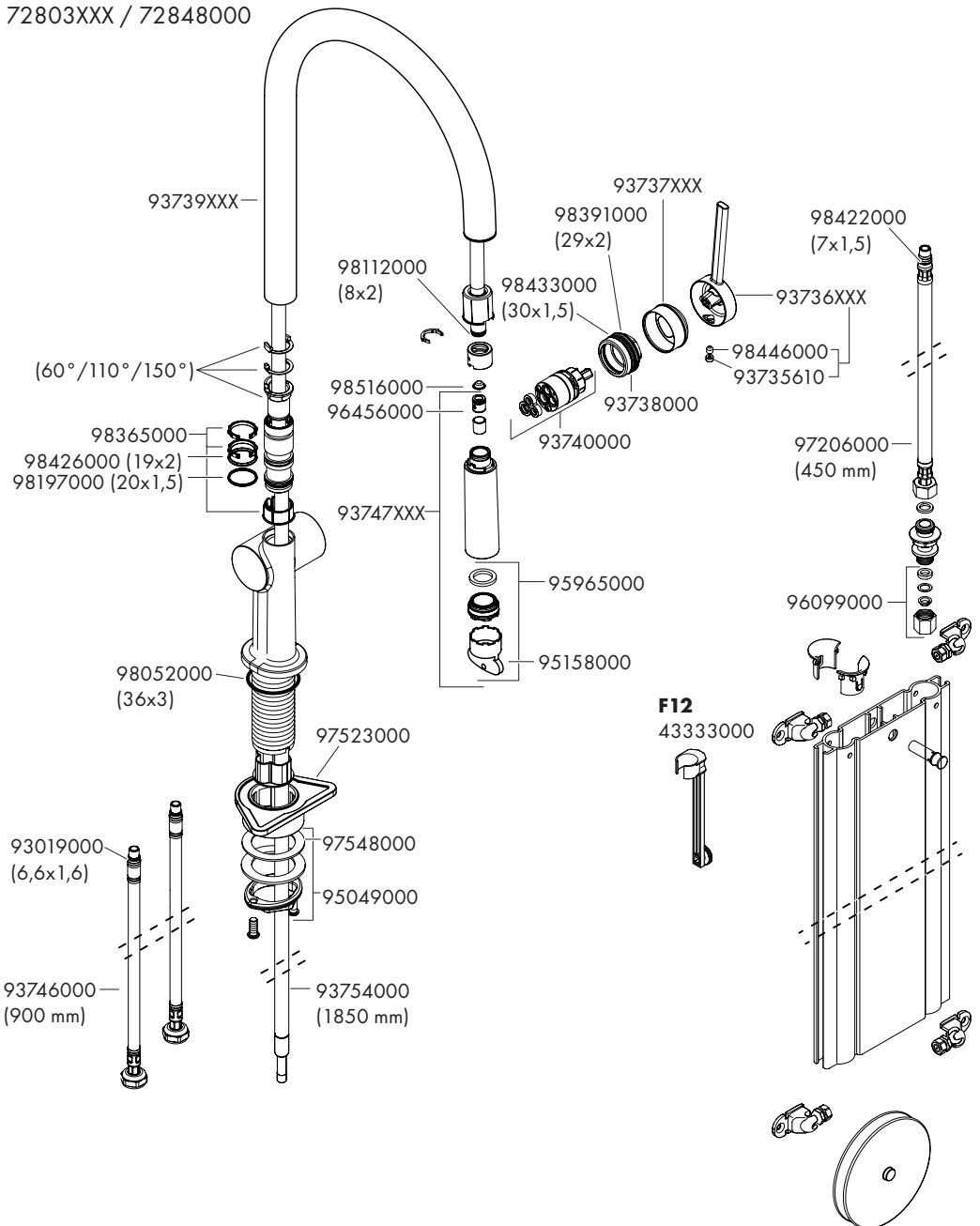



Talis M54 270 Ijet sBox

72809XXX / 72849000

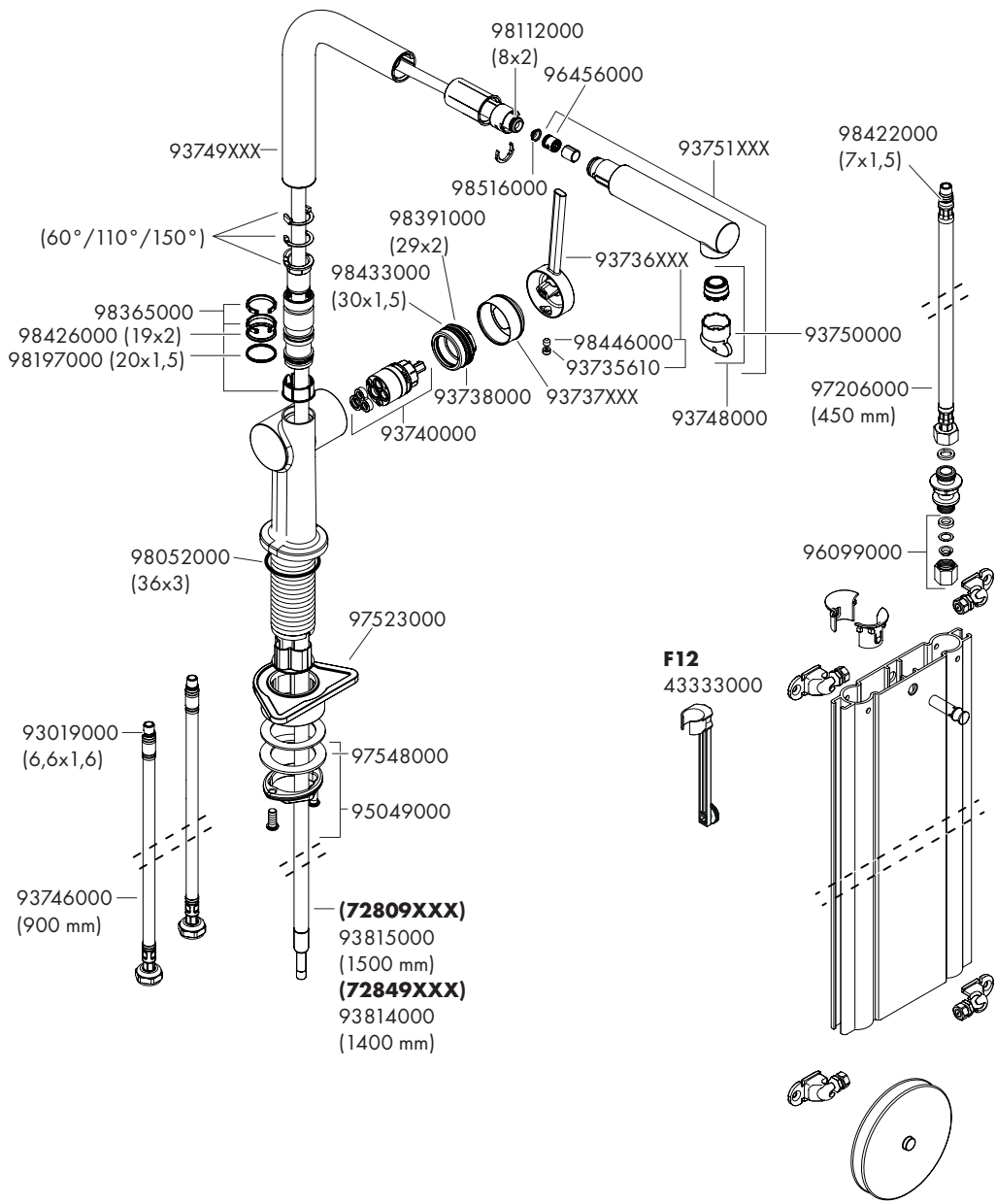



Talis M54 210 1jet sBox

72803XXX / 72848000

Talis M54 210 2jet sBox

72801XXX / 72847000

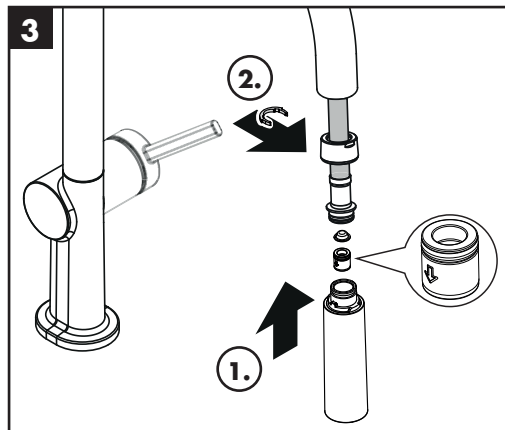
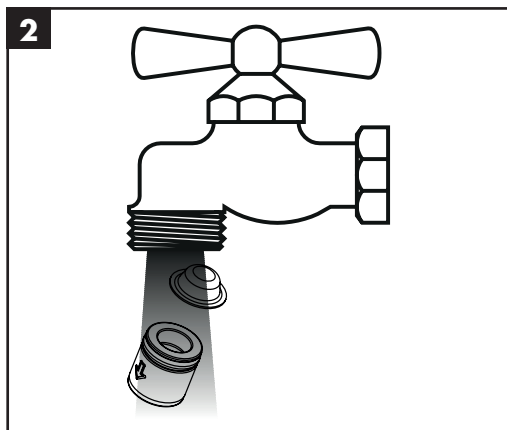
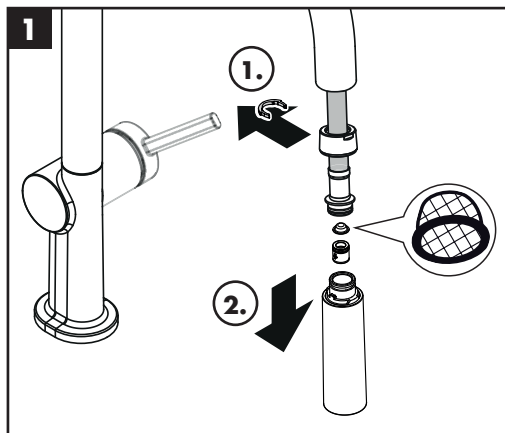



Talis M54 270 1jet sBox
72809XXX / 72849000

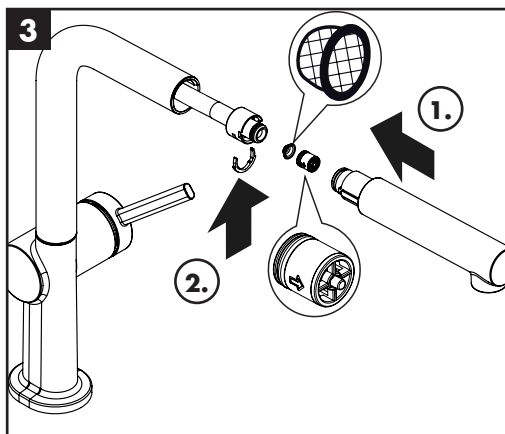
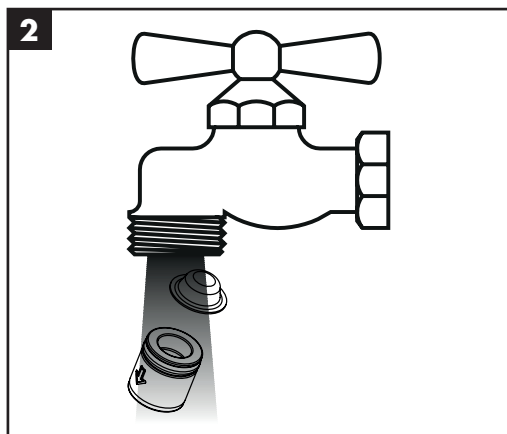
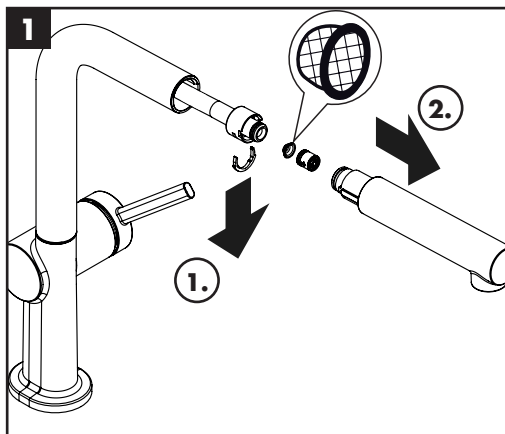



P-IX

DVGW SINTEF NF



ETA



GODKENDT TIL DRIKKEVAND

72801XXX	P-IX 29737/100	DL0136	X
72803XXX	P-IX 29738/IA	DL0136	X
72809XXX	P-IX 29741/IO	DL0136	X
72847000			X
72848000			X
72849000			X

Hansgrohe SE	Hansgrohe SE	Hansgrohe SE
DIN 4109-1	DIN 4109-1	DIN 4109-1
P-IX 29737/100	P-IX 29738/IA	P-IX 29741/IO

Достоверную информацию уточняйте на santehnica.ru.